

TEXAS DEPARTMENT OF TRANSPORTATION

Motor Carrier Handbook

Oversize/Overweight Vehicles and Loads



August 2010

Issued by the
Motor Carrier Division (MCD)
Austin, Texas

Title VI Related Statutes Nondiscrimination Statement

The Texas Department of Transportation, as a recipient of federal financial assistance and under Title VI of the Civil Rights Act of 1964 and related statutes, ensures that no person shall on the grounds of race, religion (where the primary objective of the financial assistance is to provide employment per 42 U.S.C. § 2000d-3), color, national origin, sex, age or disability be excluded from participation in, be denied the benefits of, or otherwise be subjected to discrimination under any department programs or activities.

FOREWORD

To provide for the safe, effective and efficient movement of people and goods, the Texas Department of Transportation (TxDOT) is charged by the Texas Legislature with:

- Issuing permits for the movement of oversize and/or overweight vehicles and loads
- Investigating and enforcing permit and size and weight rules and regulations.

To accomplish these charges, TxDOT adopted rules under: 43 Texas Administrative Code Chapter 28.

This handbook is available:

- On the Internet at: www.txdot.gov
search “Publications Motor Carrier”
- By contacting:
TxDOT, Motor Carrier Division (MCD)
Bull Creek
125 E. 11th Street
Austin, TX 78701-2483
1-800/299-1700

PURPOSE

The purpose of the *Motor Carrier Handbook* is to provide general references and to familiarize the motor carrier industry and general public with the applicable state rules and regulations, policies and procedures that pertain to oversize/overweight vehicles and loads in Texas.

The *Motor Carrier Handbook* also contains additional information on temporary registration, motor carrier safety, compliance and enforcement and state and federal contacts.

The information provided in the Handbook covers Texas rules and regulations regarding oversize/overweight vehicle operations. Since the material in the Handbook is informational in nature, it should not be used to cite law.

For further information:

- Refer to the legal references cited throughout this handbook
- Visit the TxDOT Web site at: www.txdot.gov search “Motor Carrier”
- Call the Motor Carrier Division at 1-800/299-1700.

Applications and forms are available:

- On the TxDOT Web site at: www.txdot.gov search “Motor Carrier Forms”
- By calling the Motor Carrier Division at 1-800/299-1700, option 0.

TABLE OF CONTENTS

Policy and Procedures

Oversize/Overweight Vehicles and Loads Permits

Permit Types	9
Permit Applications and Forms	12
Permit Office Days and Hours of Operation	15
Route Obstructions	15
Movement Restrictions.....	16
Vehicle Registration	17
Permit Application	17
Load Dimensions, Weight, Height, Length and Escort Requirements	22
Vehicle Length Diagrams	25
Highway Maintenance Fees	30
Vehicle Supervision Fees	31
Permissible Weight Guide	31
Steering/Single-Axle Load Limits	34
Load Escort Pilot Car Requirements	35
Manufactured Housing	37
Escort Pilot Car and Equipment Requirements for Manufactured Housing	40
Laws of the Texas Department of Housing and Community Affairs, Manufacturing Housing	41
Implements of Husbandry (Agriculture)	42
Portable Building Units	45
Oil Well Servicing and Drilling Machinery	46
Unladen Lift Equipment Motor Vehicles (Motor Cranes)	47
Permits for Over Axle and Over Gross Weight Tolerances	48

Fee Based on Number of Counties Traveled	50
Port of Brownsville Port Authority Permits	51
Chambers County Permits	52
Compliance	53
Records and Inspections	54
Enforcement	55

Temporary Registration (TxDMV)

Temporary Vehicle Registration	59
72-Hour and 144-Hour Temporary	59
One-Trip Temporary	60

Other Helpful Information

Motor Carrier Forms and Publications	63
Motor Carrier Important Notices and Rules/Regulations	63
Motor Carrier Safety	63
Commercial Driver License (CDL)	63
TxDOT Toll-Free Automated Telephone Menu	64
TxDOT District Offices	67
Commonly Used Terms	68
Texas State Contacts	71
Railroad Crossings Emergency Hotline	73
Federal Contacts	75

Oversize/Overweight Vehicles and Loads Permits

Permit Types

Overview. All vehicles and loads exceeding legal size or weight limits set forth by Texas Transportation Code (TRC), Chapters 621 - 623, must obtain permits according to the following table:

Permit Types	Fee	TRC Statute	Description
General Oversize/Overweight	\$60 plus highway maintenance fee when load exceeds 80,000 pounds. (See Highway Maintenance Fees table in the Load Weight subsection)	§§623.071–623.082	The basic permit law provides for the movement of oversize/overweight loads that cannot be reasonably dismantled. This law allows for the issuance of oil field drill pipe or drill collars stored in a pipe box that are overweight to be transported over farm-to-market and ranch-to-market roads.
Manufactured Housing	Single-Trip \$40 Annual \$1,500	§§623.091–623.104	Provides for the issuance of single-trip or annual permits for the movement of manufactured housing.
30-Day 60-Day 90-Day Width	\$120 \$180 \$240	§§623.071–623.082	Provides for the issuance of 30-day, 60-day, or 90-day permits for the transportation of loads that cannot be reasonably dismantled and do not exceed 13 feet wide.
30-Day 60-Day 90-Day Length	\$120 \$180 \$240	§§623.071–623.082	Provides for the issuance of 30-day, 60-day, or 90-day permits for the transportation of loads that cannot be reasonably dismantled and do not exceed 110 feet long.
Annual Envelope	\$4,000	§§623.071–623.082	Provides for the issuance of an annual permit for the transport of loads that cannot be reasonably dismantled and do not exceed 12 feet wide, 14 feet high, 110 feet long, and 120,000 pounds. These permits may be issued to a specific vehicle or a specific company.

Permit Types

Permit Types	Fee	TRC Statute	Description
Over Axle/ Over Gross Weight Tolerances (HB2060/ HB1547)	Base fee \$75 plus Administrative fee \$5 plus a sliding scale fee, based on the number of counties selected	§§623.011– 623.016	Provides for the issuance of an annual permit for vehicles hauling loads what can be reasonably dismantled within certain weight tolerances above legal axle and gross weight limits. Allows for travel on state and county roads in counties selected on the permit; excluding interstate highways, which includes main lanes and frontage roads. No travel on load posted bridges with weights exceeding posted limits, unless the bridge provides the only public vehicular access to or from the permittee’s origin or destination. Two types available: • Agricultural (allows up to 10% above legal axle weight but not more than 5% above gross vehicular weight) and • Agricultural (allows up to 12% above legal axle weight on one tandem, 10% on the remaining axels but not more than 5% above gross vehicular weight).
Portable Building Units and Compatible Cargo	\$15	§§623.121– 623.130	Provides for the issuance of single-trip permits for the movement of portable buildings and compatible cargo.
Oil Well Servicing Units and Oil Well Drilling Rigs (Single-Trip and Quarterly Permits)	\$31 or calculated fee	§§623.141– 623.150	Provides for the issuance of single-trip and quarterly permits for the movement of oil well servicing and drilling vehicles.
Oil Well Serving Units and Oil Field Rig-up Trucks (Annual Permit)	\$52 per axle	§§623.141– 623.150	Provides for the issuance of annual permits for the movement of oil well servicing and drilling vehicles.
Mobile Cranes (Annual Permit)	\$100	§623.181, §623.182	Provides for the issuance of annual permits for the movement of unladen lift equipment motor vehicles (motor cranes).

Oversize/Overweight Vehicles and Loads Permits

Permit Types	Fee	TRC Statute	Description
Mobile Cranes (Single-Trip and Quarterly Permits)	\$31 or calculated fee	§§623.191–623.200	Provides for the issuance of single-trip and quarterly permits for the movement of unladen lift equipment motor vehicles (motor cranes).
Annual Water Well and Implements of Husbandry	\$270 plus highway maintenance fee	§§623.071–623.082	Provides for the issuance of an annual permit for the transportation of farm equipment or water well drilling equipment.
Hay (Annual Permit)	\$10	§623.017	Provides for the issuance of an annual permit for the transport of cylindrically shaped bales of hay that exceed legal width up to 12 feet wide.
Utility Poles (Annual Permit)	\$120	§§622.051–622.053	Provides for the issuance of an annual permit for the transportation of utility poles, required for the maintenance of electric power transmission/distribution lines, provided the length shall not exceed 75 feet including vehicle.
Port of Brownsville Port Authority Permit	\$80	§§623.210–623.219 §§623.050–623.230	Provides an optional procedure for the issuance of a permit for the movement of oversize or overweight vehicles carrying cargo on state highways located in counties contiguous to the Gulf of Mexico or a bay or inlet opening into the gulf and bordering the United Mexican States.
Victoria County Navigation District Permit	\$30		Provides an optional procedure for the issuance of an oversize/overweight permit by Victoria County Navigation District for movement on certain state maintained highways in such county. Gross weight not to exceed 125,000 pounds.
Chambers County Permit	\$30		Provides an optional procedure for the issuance of an overweight permit by Chambers County for the movement on certain state maintained highways in such county. Dimensions and weight not to exceed 12 feet wide, 16 feet high, 110 feet long or 100,000 pounds gross weight.

Annual envelope permit. An annual envelope permit will be sent to the permitted customer by registered mail or at the customer's request and expense, by overnight delivery service. This permit may not be duplicated. This permit will be replaced only if:

- The permitted customer did not receive original permit within seven business days after its date of issuance;
- A request for replacement is submitted to the department within 10 business days after its date of issuance; and
- The request for replacement is accompanied by a notarized statement signed by a principle or officer of the permittee acknowledging that the permittee understands the permit may not be duplicated and that if the original permit is located, the permittee must return either the original or replacement permit to the department.

A request for replacement of a permit issued will be denied if TxDOT verifies that the permit customer received the original.

Lost, misplaced, damaged, destroyed or otherwise unusable permits will not be replaced. A new permit is required.

Permit Applications and Forms

To submit an oversize/overweight permit application electronically, or to download a form, go to the TxDOT Web site at: www.txdot.gov and search "Motor Carrier Forms." Following is a list of permit applications and forms:

Oversize/Overweight Vehicles and Loads Permits

Permit Forms	Form #
Affidavit of Exception - Motor Crane/Well Service Unit	204
Annual Oversize/Overweight Envelope Permit, Application/Renewal	301
Annual Oversize/Overweight Envelope Permit, Cash Application	301c
Annual Oversize/Overweight Exempt Envelope Permit, Application/Renewal	301a
Annual Permits, Application/Renewal - <i>Annual Well Servicing Unit</i> - <i>Annual Implement of Husbandry</i> - <i>Annual Rig-Up Truck</i> - <i>Annual Mobile Crane</i> - <i>Annual Water Well Drilling</i> - <i>Annual Fracing Trailer</i> - <i>Annual Manufactured Housing</i>	302
Annual Permits, Cash Application/Renewal	302c
Concrete Beam/Girder (HB2093) Facsimile Application	2234
General Permit Facsimile Application - <i>Single Trip and</i> - <i>Temporary Registration</i>	106
General Permit Cash Payment Facsimile Application	106c
General Permit Multiple Load Sheet	103
Manufactured Housing Permit Facsimile Application	102
Manufactured Housing Permit – Cash Payment Facsimile Application	102c
Over Axle and Over Gross Weight Tolerance Permit Application	1751
Over Axle and Over Gross Weight Tolerance Permit Bond	1753

Oversize/Overweight Vehicles and Loads Permits

Permit Forms	Form #
Permit Movement Conditions and Curfews - Supplement Sheet	001
Pre-Approved House Move Route Form	109
Procedures for Time Permits	304
Procedures for Annual Oversize/Overweight Permits	304a
Ready-Mix Concrete & Concrete Pump Truck Surety Bond	1382
Ready-Mix Concrete & Concrete Pump Truck Surety Bond Certification	1382a
Ready-Mix Concrete & Concrete Pump Truck Surety Bond Amendment	1383
Route Inspection/Permit Application	306a
Shipper Certificate of Weight	2280
Specific Time Permits, Application/Renewal - <i>30/60/90 Day Width</i> - <i>30/60/90 Day Length</i> - <i>Annual Hay Permit</i> - <i>Annual Pole Permit</i>	302a
Specific Time Permits, Cash Application/Renewal	303c
Solid Waste and Recyclable Materials Surety Bond	1575
Solid Waste and Recyclable Materials Surety Bond Certification	1576
Solid Waste and Recyclable Materials Surety Bond Amendment	1577
Super Heavy Application Packet	305
Superheavy or Oversize Permit Bond	439
Temporary Registration Facsimile Application	1710
Texas Self-Issue Application and Permit to Move Oversize or Overweight Equipment or Loads Over State Highways	1700
Western Regional (WASHTO) Permit Application	400
Weight Supplement Sheet for Annual Envelope Permits	300a

Permit Office Days and Hours of Operation

Days	Hours	Calls*/Applications Accepted
Monday - Friday	6 a.m. - 6 p.m.	6 a.m. - 5:45 p.m.
Saturday	6 a.m. - 2 p.m.	6 a.m. - 1:45 p.m.
Sunday	Closed	
* Our telephone system will only accept calls between these times.		

Closures. The TxDOT Motor Carrier Permit Office is closed on Sunday and the following holidays:

- New Year's Day
- Memorial Day
- Independence Day
- Labor Day
- Thanksgiving Day and the Friday following Thanksgiving Day
- Christmas Eve Day and Christmas Day
- The Saturday before any of the holidays listed above when the holiday falls on a Monday, except for the Saturday before Christmas Eve Day when Christmas Eve falls on a Monday
- The Saturday after any of the holidays listed above when the holiday falls on a Friday, except for the Saturday after Thanksgiving Day and the Saturday after Christmas Day when Christmas Day falls on a Friday
- At other times deemed necessary by TxDOT's administration, such as in the case of emergency weather conditions.

Route Obstructions

It is the responsibility of the permittee to contact utility, telephone and television cable companies, or other entities as may be required and when it is necessary to raise or

lower any overhead wire, traffic signal, street light, television cable, sign, or other overhead obstruction.

The permittee obtaining a permit is responsible for providing the appropriate advance notice as required by each utility entity.

Movement Restrictions

Daylight movement. A permitted vehicle may be moved only during daylight hours unless it meets required criteria for night movement. Daylight is 30 minutes before sunrise and 30 minutes after sunset.

Night movement. A permitted vehicle may be granted night movement when it:

- Is only overweight on any state maintained road
- Is traveling on an interstate highway and does not exceed 10 feet wide and 100 feet long, with legal front and rear overhangs
- Is overweight and meets the criteria in the second bulleted item
- Is a mobile crane not exceeding 10 feet 6 inches wide, 14 feet high, or 95 feet long on any state maintained road
- Is a self-propelled oil well servicing unit not exceeding 9 feet wide on any state maintained road

TxDOT may grant an exception allowing for night movement to certain loads in cases of emergency, such as for movement of utility poles to restore or prevent interruption of electrical service, or equipment needed to clear and restore railroad tracks in case of a train derailment. These emergency loads must have front and rear escorts.

Utility poles. Vehicles permitted to move utility poles may not travel over a load-restricted bridge or a load-zoned road when exceeding the posted weight limits.

Reduced visibility. Movement is prohibited when visibility is reduced to less than two-tenths of one mile or the road surface is hazardous due to:

- Weather conditions such as wind, rain, ice, sleet, or snow
- Highway maintenance or construction work.

Heavy traffic conditions. TxDOT may limit the hours for travel on certain routes because of heavy traffic conditions.

Holiday restrictions. Loads exceeding 14 feet wide, 16 feet high and 110 feet long may not be transported on New Year's Day, Memorial Day, Independence Day, Labor Day, Thanksgiving Day and Christmas Day.

For manufactured housing movement restrictions, see subsection titled, "Manufactured Housing, Movement Restrictions."

Vehicle Registration

Motor carriers must have proper vehicle registration. This includes Texas license plates that indicate the permitted vehicle is registered for maximum legal gross weight or the maximum weight the vehicle can transport, Texas temporary vehicle registration, out-of-state license plates that are apportioned for travel in Texas and foreign commercial vehicles registered under Texas annual registration. Visit the Texas Department of Motor Vehicles at www.txdmv.gov for more information.

Permit Application

A permit may be obtained by Internet, fax, telephone, mail, Remote Permit System (RPS) or a third-party service provider (wire services).

Required information. To reduce the time it takes to receive a permit, have the following required information readily available before you apply:

1. Customer permit account number
2. Payment type: TxDOT-approved credit cards (MasterCard, American Express, Discover, VISA), pre-established escrow account (with TxDOT Finance) or FirstPay. A service charge is applied to each credit card transaction
3. Current truck and trailer information including:
 - o Year and make
 - o Vehicle identification number (VIN)
 - o License number and name of issuing state
4. Complete load description
5. Load dimensions including:
 - o Width
 - o Height
 - o Length (including length of truck, trailer, and overhang)
 - o Overhang (exceeding 4 feet rear or 3 feet front)
 - o Gross weight (when applicable: axle weights, axle spacings, tire size)
6. Route information including the most practical route that will accommodate the load from an exact point of origin to an exact point of destination on the state highway system
7. Permit movement date (must include enough time to make the move)

For required information on manufactured housing, modular homes, industrialized houses and industrialized buildings see subsection titled, “Manufactured Housing, Application Requirements.”

Submitting by Internet. The Internet allows one to apply for a permit, 24 hours a day, 7 days a week. By using the Internet, applicants can avoid telephone hold time, filling

out forms and possible delays in receiving permits. Applications will be processed during normal business hours.

To obtain a customer account number, logon and/or password:

- E-mail the Motor Carrier Division at mcd-respond@txdot.gov
- Type “CPS Logon” in the subject line
- Include the company’s name, address and customer account number (if known) and the contact’s name, telephone number, fax number and e-mail address in the body of your e-mail.

This requires one to three business hours to activate.

After obtaining a customer account number and logon ID, at www.txdot.gov select “Get an oversize/overweight permit?” from the “How Do I...” drop down search list. then select “Online Permits (CPS).”

Permit forms. Forms may be obtained from:

- www.txdot.gov
search “Motor Carrier Forms” or
- 1-800/299-1700, option 0

By fax. To fax an oversize/overweight permit application form to TxDOT, complete the appropriate permit form and fax to 512/465-3565.

By telephone. The following process is for getting a permit by telephone:

1. Gather all required information (see “Required Information” in this section).
2. Call 1-800/299-1700 (for official record, all calls are recorded), options 1, 7, 1

3. A permit application specialist enters the required information into the online permit system.
4. The applicant is given a permit ID number.
5. The application is placed into the system in the order it was received together with other permit applications received by phone, fax and online.
6. A permit specialist processes the application and verifies the route.
7. An official permit is issued to the customer by method indicated at the time of application.
8. The permit must be carried in the cab of the vehicle for which it was issued until the day after the expiration date.

By Remote Permit System (RPS) program. The TxDOT RPS program allows customers to process their own oversize/overweight permit applications, within specified parameters, over the Internet, 24 hours a day, 7 days a week. Customers participating in the Remote Permitting System must meet a minimum accuracy rating each month to remain in the program.

To apply for a permit using the RPS program, a customer must have Internet access and must enter into an agreement with TxDOT as follows:

- The customer contacts TxDOT to obtain the RPS program description/instructions (can be done by letter or by telephone 1-800/299-1700)
- TxDOT and customer negotiate maximum dimensions
- TxDOT reviews the maximum dimensions to determine eligibility and drafts a contract
- The customer and the TxDOT Motor Carrier Division director sign the contract
- TxDOT provides permit process training to the customer and employees
- TxDOT provides a district permit map and instructs customers regarding map use and how to post changes and restrictions.

The training process also includes routing, special conditions, approvals, the quality assurance process and any other items that may be specific to the customer. Training lasts up to four weeks, depending on the level of permit knowledge the customer already has.

- When training is complete, the customer is assigned a logon ID and password to sign on to the Central Permit System and to begin issuing permits.

For additional information on the RPS program, contact us at 1-800/299-1700, options 1, 4.

Proof of permit. The original permit, a fax copy of the permit, or a TxDOT computer-generated permit must be kept/carried in the cab of the vehicle for which it was issued until the day after the permit's expiration date.

Refunding, amending and voiding a permit. A permit fee will not be refunded after the permit number has been issued unless such refund is necessary to correct an error made by a permit specialist.

A permit may be amended for the following reasons:

- Vehicle breakdown
- Changing the intermediate points in an approved permit route
- Extending the expiration date due to weather or breakdown conditions which would cause the move to be delayed
- Changing the route origin and destination can only be done before the start date as listed on the permit
- Size of the load (may only be changed before the start date of the permit and only when the route will not be affected by the size change. If the permit has started, or the size change affects the route, a new permit must be obtained).

Under Administrative Enforcement a permit may be revoked.

For more information. Visit the TxDOT Web site at www.txdot.gov (search “Motor Carrier”).

Load Dimensions, Weight, Height, Length and Escort Requirements

Load Width

Width is measured from outside points of the widest extremities, excluding safety devices. Legal width limit is 8-1/2 feet.

Permit/Movement Conditions	Maximum Width (in feet)
30-day, 60-day, or 90-day permit	13
On holidays	14
On interstate highways	16
Without route and traffic studies	20
New storage tanks	34*
New houses	34*
Manufactured housing	Unlimited
Portable building units	Unlimited
*A permit will not be issued for an existing house or storage tank that exceeds 40 feet overall width, unless TxDOT grants an exception based on a route and traffic study.	

Route and Traffic Studies. A vehicle operator carrying a load exceeding 20 feet or wider must physically inspect a proposed route and certify to TxDOT by letter or fax that the overwidth load can safely negotiate the route.

Escort Pilot Car requirements. One escort is required for all loads exceeding 14 feet up to 16 feet wide with the exception of manufactured housing and portable building units.

Two escorts are required for all loads exceeding 16 feet wide, with the exception of manufactured housing and portable building units.

The escort must precede the load on a two-lane highway to warn oncoming traffic of the approaching overwidth load.

The escort must follow the load on a roadway of four or more lanes to warn approaching traffic of the overwidth load.

Load Height

Height refers to loaded height and extends from the roadbed to the highest point of the load. Legal height limit is 14 feet.

Height Permitted

Permit/Conditions Types	Maximum Height (in feet)
On holidays	16
Without route and traffic studies	18 feet, 11 inches

Overheight load. A vehicle operator carrying a load 19 feet or higher must physically inspect a proposed route and certify to TxDOT by letter or fax that the overheight load can safely negotiate all power, communication and cable television lines and all other low vertical obstructions.

Escort Pilot Car requirements. One front escort is required for loads exceeding 17 feet in height.

The escort must be equipped with a height pole to accurately measure overhead obstructions.

Front and rear escorts are required for loads exceeding 18 feet in height. The front escort pilot car must be equipped with a height pole to accurately measure overhead obstructions.

Load Length

The following table lists the legal length for each type of vehicle or combination of vehicles and the maximum length permitted.

Length Permitted

Permit/Condition Type		Legal Length (in feet)	Maximum Length (in feet)
Truck or single vehicle		45	75
Truck and trailer combination		65	Unlimited
Truck-tractor		Unlimited	Unlimited
Truck-tractor combination	Overall length	Unlimited	N/A
	Trailer	59	
Semitrailer	Single unit	59	N/A
	Double bottom	28-1/2	
Front overhang		3	25
Rear overhang		4	30
Maximum overall length			Unlimited
Maximum length permitted without route and traffic study and route certification by applicant on file			125
Maximum length permitted on holidays			110

Overlength load. The overall length (including an overhang) must be listed on the permit and the length of the overhang must be listed separately on the permit.

Escort pilot car requirements. Loads exceeding 110 feet, but not exceeding 125 feet long and 20 feet front and/or rear overhang, require one escort.

Loads exceeding 125 feet in length require front and rear escorts.

Vehicle Length Diagrams

Length limits as they apply to motor vehicles other than truck tractors

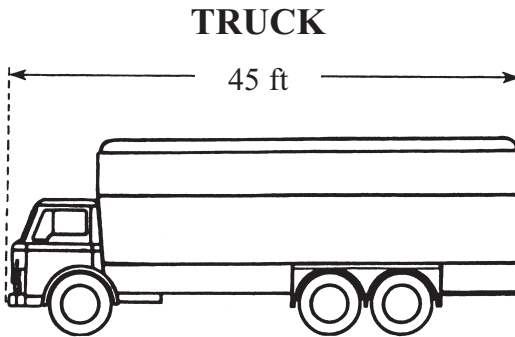

No motor vehicle other than a truck tractor shall exceed a length of 45 feet.

Length Requirements for Tractor

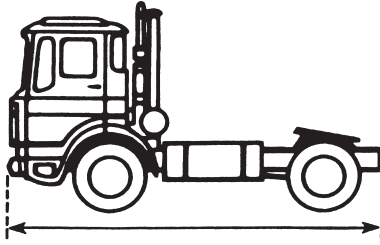

There is no length limitation for a tractor.

Truck and Trailer Combination

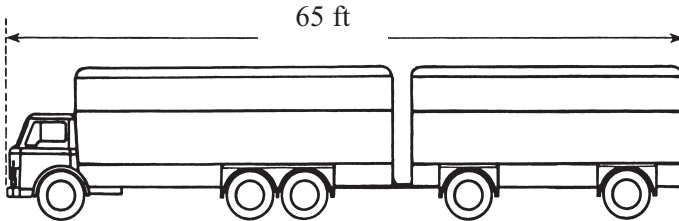

No truck and trailer operated in combination shall exceed 65 feet in overall length.

Truck and Semitrailer Combination

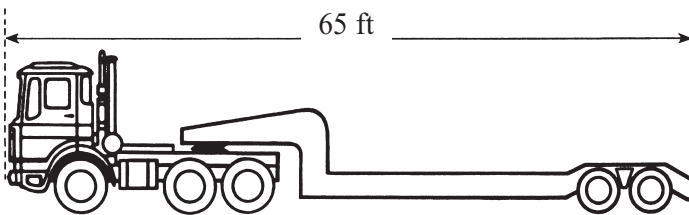

No truck and semitrailer shall exceed a total length of 65 feet.

Truck and Trailer Combination

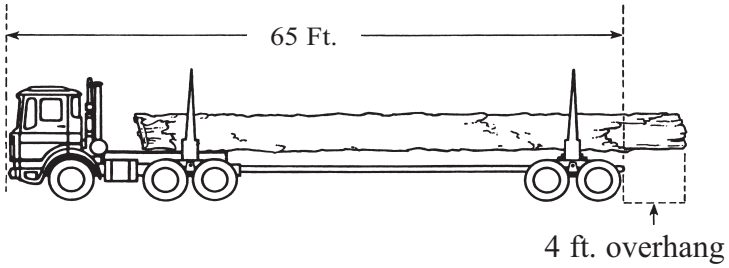

No truck and pole trailer combination shall exceed a total length of 65 feet.

Truck Tractor, Semitrailer, Trailer Axle Converter and Semitrailer Combination

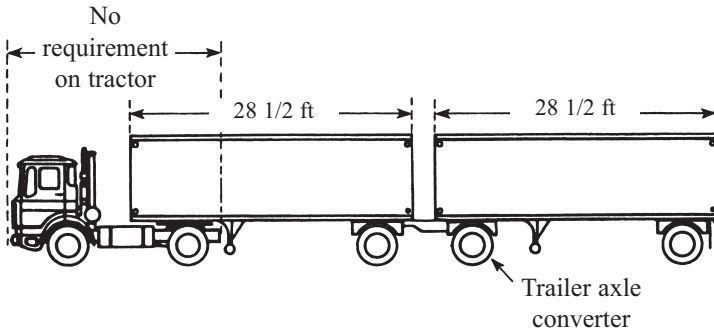

Each semitrailer and trailer operated in a truck-tractor, semitrailer, trailer combination would be limited to 28-1/2 feet. There is no length limitation for a truck tractor or overall length limitation for this combination.

Truck Tractor, Semitrailer Combination

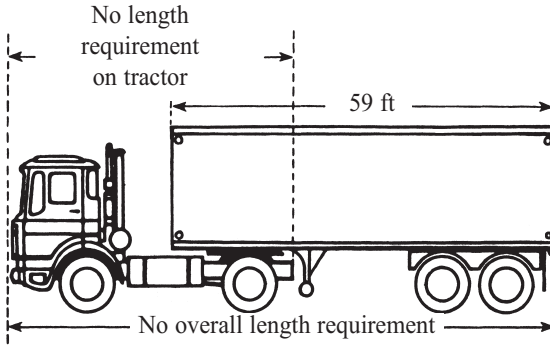

A semitrailer operated in a truck tractor, semitrailer combination would be limited to 59 feet. There is no length limitation for a truck tractor or overall length limitation for this combination. Length limitation on a semitrailer is described in terms of the distance from the kingpin to rearmost axle or end of semitrailer.

Load Weight

The number of axles and the distance between the axles is the basis for maximum legal weight. This information, in conjunction with the Permissible Weight Guide, is used to determine maximum legal weight for a vehicle.

Definitions. The following terms are used to explain the procedure:

- **Drive axles** - The axles that power a vehicle.
- **Inner bridge distance** - The distance from the center of the first drive axle to the center of the last trailer axle.
- **Outer bridge distance** - The distance from the center of the steering axle of the truck to the center of the last trailer axle.
- **Steering axle** - The front axle of the truck.
- **Tandem axle weight** - The total weight transmitted to the road by two or more consecutive axles whose centers may be included between two parallel transverse vertical planes spaced more than 40 inches and not more than 96 inches apart, extending across the full width of the vehicle.
- **Trunion axle** - Two individual axles mounted in the same transverse plane, with four tires on each axle, that are connected to a pivoting wrist pin that allows each individual axle to oscillate in a vertical plane to provide for constant and equal weight distribution on each individual axle at all times during movement.
- **Trunion axle group** - Two or more consecutive trunion axles whose centers are at least 54 inches apart and are individually attached to (or articulated from, or both) the vehicle by a weight equalizing suspension system.

Maximum Legal Weights

- Gross weight cannot exceed 80,000 pounds.
- Weight for a single axle cannot exceed 20,000 pounds.
- Weight for a tandem axle group cannot exceed 34,000 pounds.
- Weight for a tri-tandem axle group cannot exceed 42,000 pounds.

Permit Fees

- Weight up to 80,000 pounds. Single-trip, overweight permit: \$60 (including when axle(s) exceed legal weight, but overall does not exceed 80,000 pounds)
- Weight exceeding 80,000 pounds. In addition to the \$60 single-trip, overweight permit fee, vehicles exceeding 80,000 pounds must also pay a highway maintenance fee according to the following table:

Highway Maintenance Fees

Gross Weight in Pounds	Highway Maintenance	Permit	Total
80,001-120,000	\$150	\$60	\$210
120,001-160,000	\$225	\$60	\$285
160,001-200,000	\$300	\$60	\$360
200,001- more*	\$375	\$60	\$435
* Weight exceeding 200,000 pounds. In addition to the \$375 highway maintenance fee, vehicles exceeding 200,000 pounds must also pay a vehicle supervision fee according to the following table.			

Vehicle Supervision Fees

Criteria	Vehicle Supervision Fee
200,001-254,300 pounds total and at least 95 feet overall axle spacings and not exceeding the maximum permissible weight on any axle or axle group	\$35
200,001-254,300 pounds total and less than 95 feet overall axle spacings, or over the maximum permissible weight on any axle or axle group, or over 254,300 pounds gross weight	\$500
For multiple permits ordered within 30 days of approval (For super heavy process only)	\$35
When no bridges are crossed (For super heavy process only)	\$100
For more information regarding vehicle supervision fees, contact TxDOT at 1-800/299-1700.	

Permissible Weight Guide

The following table provides a permissible weight guide to the maximum weight on any group of two or more consecutive axles. This information may be applied to inner axle groups, such as the drive axles and the trailer or trailers, or the entire combination of axles from the steering axle of the power unit to the last trailing axle of the trailer.

The number in the left most column is the required distance in feet between the extremes of any group of two or more consecutive axles.

The remaining column indicates the maximum weight for various numbers of axles in the group of axles being considered.

The maximum weights shown in the table are based on either of these formulas:

$$W=500 [(LN/(N-1)) +12N+36]$$

L=length & N= # of axles

or

- Weights that are legal as of December 16, 1974, as provided in *Subsection (4), TCS Article 6701d-11, Section 5*. The weights for any group of two or more axles for vehicles that could legally be operated before December 16, 1974, were based on the table values contained in the statutes.

Permissible Weight Guide

Distance in Feet	2 axles	3 axles	4 axles	5 axles	6 axles	7 axles
4	34,000					
5	34,000					
6	34,000					
7	34,000					
8	34,000	34,000				
8+	38,000	42,000				
9	39,000	42,500				
10	40,000	43,500				
11		44,500				
12		45,000	50,000			
13		45,500	50,500			
14		46,500	51,500			
15		47,500	52,000			
16		48,000	52,500	58,000		
17		48,500	53,500	58,500		
18		49,900*	54,000	59,000		
19		51,400*	54,500	60,000		
20		52,800*	55,500	60,500	66,000	
21		54,000*	56,000	61,000	66,500	
22		54,000*	56,500	61,500	67,000	
23		54,000*	57,500	62,500	68,000	
24		54,000	58,700*	63,000	68,500	74,000
25		54,500	59,650*	63,500	69,000	74,500

Permissible Weight Guide (cont.)

Distance in Feet	2 axles	3 axles	4 axles	5 axles	6 axles	7 axles
26		55,500	60,600*	64,000	69,500	75,000
27		56,000	61,550*	65,000	70,000	75,500
28		57,000	62,500*	65,500	71,000	76,500
29		57,500	63,450*	66,000	71,500	77,000
30		58,500	64,000*	66,500	72,000	77,500
31		59,000	65,350*	67,500	72,500	78,000
32		60,000	66,300*	68,500	73,000	78,500
33			67,250*	68,500	74,000	79,000
34			68,200*	69,000	74,500	80,000
35			69,150*	70,000	75,000	
36			70,100*	70,500	75,500	
37			71,050*	71,050	76,000	
38			72,000*	72,000*	77,000	
39			72,000 *	72,500	77,500	
40			72,000 *	73,000	78,000	
41			72,000 *	73,500	78,500	
42			72,000 *	74,000	79,000	
43			72,000 *	75,000	80,000	
44			72,000 *	75,500		
45			72,000	76,000		
46			72,500	76,500		
47			73,500	77,500		
48			74,000	78,000		
49			74,500	78,500		
50			75,500	79,000		
51			76,000	80,000		

* These figures were carried forward from *Article 6701d-11, §5(a)(4)* when Senate Bill 89 of the 64th Legislature amended it on December 16, 1974. The amendment provided that axle configurations and weights that were lawful as of that date would continue to be legal under the increased weight limits.

+ This figure applies only to an axle spacing greater than 8 feet, but less than 9 feet.

Load Per Tire. Weight on any:

- High-pressure tire may not exceed 600 pounds per inch of tire width and no wheel load may exceed 8,000 pounds
- Low-pressure tire may not exceed 650 pounds per inch of tire width and no wheel load may exceed 10,000 pounds.

A permit does not authorize the vehicle to exceed the following manufacturers' tire load rating *FMCSR* §393.75f.

Steering/Single-Axle Load Limits

The formula below determines the load limit for a steering or single axle with only two tires:

$$\text{Number of Tires} \times \text{Tire Tread Width (inches)} \times \text{Tire Load Limit (PSI)} = \text{Axle Load Limit}$$

The following table gives the axle load limits for 650 PSI: Axle Load Limits for 650 PSI Tires

Number of Tires (per axle)	Tire Size (in inches)	Tire Size (in millimeters)	Tire Load Limit PSI	Axle Load Limit (in pounds)
2	10	245-265	650	13,000
2	11	270-290	650	14,300
2	12	295-315	650	15,600
2	13	320-340	650	16,900
2	14	345-365	650	18,200
2	15	370-390	650	19,500
2	16	395-415	650	20,800
2	17	420-440	650	22,100
2	18	445-465	650	23,400

Axle Load Limits (Permitted)

Tire Load Limit (in pounds) PSI	Size of Tires (Metric Sizes in Millimeters)						
	10:00 (245-265)	11:00 (270-290)	12:00 (295-315)	13:00 (320-340)	14:00 (345-365)	15:00 (370-390)	16:00 (395-415)
650	13,000	14,300	15,600	16,900	18,200	19,500	20,800
850	17,000	18,700	20,400	22,100	23,800		

* The maximum that can be permitted on a single axle is 25,000 pounds without performing a route study and bridge analysis. 850 pounds per inch of tire width can only be used when permitting oil well servicing units and mobile cranes under *43 Texas Transportation Code, §§ 623.142, 623.181, and 623.192.*

Load Escort Pilot Car Requirements

Dimension	Vehicle Size Exceeding	Type of Escort
Width	Exceeding 14 feet up to 16 feet	Front – two-lane highway
		Rear – divided highway
	Exceeding 16 feet	Front and rear – all roads unless TxDOT grants an exception
Height	Exceeding 17 feet	Front – equipped with height pole
	Exceeding 18 feet	Front and rear – all roads unless TxDOT grants an exception Front – equipped with height pole
Length	Exceeding 110 feet up to 125 feet	Front – two-lane highway
		Rear – divided highway
	Exceeding 125 feet	Front and rear – all roads unless TxDOT grants an exception
	Exceeding 20 feet front overhang	Front – two-lane highway
		Rear – four or more lane highway
	Exceeding 20 feet rear overhang	Rear – two-lane highway
Rear – four or more lanes highway		

Loads that exceed more than one legal dimension

When a load is over in two dimensions that require an escort, front and rear escorts are required.

Example. If a load is 16 feet wide and 112 feet long, it will require one escort for the width and one escort for the length.

Exception. If a load exceeds 110 feet, but does not exceed 125 feet in length and has a rear overhang exceeding 20 feet, only one escort is required.

For manufactured housing escort requirements, see subsection titled, “Manufactured Housing, Escort Requirements for Manufactured Housing.”

Equipment requirements for escort pilot car vehicles

- **Lights.** An escort vehicle must have two flashing amber lights or one rotating amber beacon of not less than eight inches in diameter fixed to the roof of the escort vehicle. The light must be visible from all sides of the escort vehicle.
- **Signs.** An escort vehicle must display a sign on either the roof of the vehicle or the front and/or rear of the vehicle with the words “OVERSIZE” or “WIDE LOAD.” The sign must be:
 - o Size - at least 5 feet, but not more than 7 feet in length and at least 12 inches, but not more than 18 inches in height
 - o Color - yellow background with black lettering
 - o Size of lettering - at least 8 inches high, but not more than 10 inches high with a brush stroke at least 1.4 inches wide
 - o Visibility - visible from the front and rear of the vehicle while escorting the permit load. The sign must not be used at any other time.

- **Radio.** An escort vehicle must maintain two-way communications with the permitted vehicle and other escort vehicles involved with the movement of the permitted vehicle.
- **Height pole.** Any permitted vehicle that exceeds 17 feet in height must have a front escort vehicle equipped with a height pole made of nonconductive metal to accurately measure overhead obstructions.
- **Motorcycle.** An official law enforcement motorcycle may be used as a primary escort vehicle for a permitted vehicle traveling within the limits of an incorporated city. The motorcycle must be operated by a highway patrol officer, sheriff or duly authorized deputy, or a municipal police officer.

Escort (pilot car) vehicle must be a single unit with a gross weight (GVW) of not less than 1,000 pounds nor more than 10,000 pounds.

Manufactured Housing

Carriers must have Texas Motor Carrier Registration, Unified Carrier Registration (UCR), or must be registered with the Texas Department of Housing and Community Affairs –TRC 623.091-623.104.

Permit Fees. Manufactured housing is eligible for single-trip and annual permits.

- Single-trip manufactured housing permit: \$40
- Annual manufactured housing permit: \$1,500

Single-trip permit. A single-trip permit is for single continuous movement not to exceed five days.

In the case of a *double-wide* manufactured house, moving on its own set of axles, each half requires a permit. To move the double-wide manufactured house as one unit on a set of house moving dollies requires a permit for a house move.

TxDOT considers any returnable undercarriage, temporary chassis system, or a single manufactured house frame to be component parts. For that reason, they qualify for a manufactured housing permit.

A stack of manufactured housing frames requires a regular oversize permit, which costs \$60. The applicant must have Texas Motor Carrier Registration or Unified Carrier Registration or must have a current bond on file. The stacked load must not exceed legal height or weight. The bottom frame or transporter must have either a regular Texas trailer license, or a 72/144-hour temporary vehicle registration.

Annual permit. A manufactured housing annual permit is for the transportation of a manufactured house from a manufacturing facility to a temporary storage location, not to exceed 20 miles from the point of manufacture.

Measurements. The *width* of a manufactured house includes any roof or eaves extension or overhang on either side.

The *height* extends from the roadbed to the highest point of the manufactured house.

The overall combined *length* of the manufactured house and the towing vehicle includes the length of the hitch or towing device.

The weight must be *legal*.

Identification numbers. The applicant must complete the application and include the manufactured house's Housing and Urban Development (HUD) label number, Texas Seal number, or the complete serial number of the unit being moved.

- **HUD label number.** A HUD label number is required on all houses built after June 15, 1976.
- **Texas Seal number.** A house built after June 15, 1976, that does not have a HUD label number must apply to the Texas Department of Housing and Community Affairs for a Texas seal number if the house is being sold.
- **Identification or serial number.** Pre-HUD years (before June 15, 1976) require a complete serial number.
- **Registration number or motor carrier number.** During the transportation of a manufactured house, affix the permittee's registration or motor carrier number to the rear of the manufactured house. The number is to have letters and numbers that are at least eight-inches high.

Application Requirements. Application for a manufactured housing single-trip permit must contain the following:

- Applicant name, address, phone number, account number
- When moving a manufactured house, a modular home, an industrialized house, or an industrialized building as defined in *Occupations Code 1201.001, 1202.002 and 1202.003* include the following:
 - o Manufactured house HUD label number, Texas seal number on houses manufactured after June 15, 1976, complete identification or serial number for houses manufactured before June 15, 1976
 - o Name of the owner of the manufactured house
 - o Location (physical address) from where the house is being moved unless the house is being moved from a dealer or factory
 - o Location (physical address) to where the house is being moved unless the house is being moved to a dealer or factory
- Overall length, width and height of the house and towing vehicle in combination
- Applicant's moving/operating authority number.

Escort Pilot Car and Equipment Requirements for Manufactured Housing

Escort Pilot Car Requirements

Dimensions Exceeding	Type of Highway	Type of Escort
16 feet wide, but not exceeding 18 feet wide	Divided	Rear
	Non-divided	Front
18 feet wide	All	Front and rear

Two halves of a double-wide may be moved in convoy and share the required escorts if the distance between the two units does not exceed 1,000 feet. Each unit requires its own permit.

Lights. A manufactured house over 12 feet wide is to have one rotating amber beacon not less than 8 inches in size mounted somewhere on the roof at the rear of the manufactured house.

Instead of a roof beacon, two five-inch flashing amber lights may be mounted approximately 6 feet from ground level at the rear corners of the manufactured house.

The towing vehicle is required to have one rotating amber beacon of not less than 8 inches in size mounted on the top of the cab. These beacons are to be operational and luminous during any permitted move over the highway.

Movement Restrictions

- **Heavy traffic conditions.** TxDOT may limit the hours for travel on certain routes because of heavy traffic conditions.

- **Holidays.** Manufactured housing may not be moved on:
 - o New Year's Day
 - o Memorial Day
 - o Independence Day
 - o Labor Day
 - o Thanksgiving Day
 - o Christmas Day.
- **Visibility, weather and construction.** TxDOT also prohibits movement when:
 - o Visibility is reduced to less than 2/10 of a mile
 - o The road surface is hazardous due to weather such as wind, rain, ice, snow
 - o Highway maintenance or construction work.

Laws of the Texas Department of Housing and Community Affairs, Manufactured Housing

(10 Texas Administrative Code (TAC) §80, Texas Occupation Code §1201-1202)

The Manufactured Housing Division, an independent entity of Texas Department of Housing and Community Affairs, with its own board and executive director, regulates manufactured housing in Texas, licensing those who manufacture, sell and install the homes. Additionally, they maintain a database of all home owners, provides consumer protection, installation and habitability inspections and administers the Homeowners' Recovery Trust Fund, providing consumer remedy. This regulatory authority is pursuant to the Texas Occupations Code and *Title 10, Section 80 of the Texas Administrative Code.*

It is unlawful to:

- Sell two or more manufactured homes within a 12-month period without a Texas Retailer's license.
- Construct, assemble, or ship into Texas, a new HUD Code manufactured home without a Texas Manufacturer's license.
- Install, re-level, block, anchor, or install components of a foundation, without a Texas Installer's license.

All licensed installers must report every installation which may be inspected by the Department.

Any home that has been salvaged can only be sold to or rebuilt by a licensed retailer or rebuilder, in accordance with extensive rebuilding and inspection requirements.

If the owner of a manufactured home relocates the home, the owner shall apply for the issuance of a new statement of ownership and location (formerly known as a title), within 60 days from the date of relocation and include a copy of the moving permit.

To contact the Texas Department of Housing and Community Affairs, Manufactured Housing Division, call direct at 512/475-2200 or toll-free at 1-800/500-7074, or access their Web site at www.tdhca.state.tx.us/mh/index.htm.

Implements of Husbandry (Agriculture)

(TRC §§623.071 – 623.082)

Definition. Implements of husbandry are:

- Farm implements
- Machinery and tools (does not include passenger car or truck) used in tilling the soil and harvesting the resulting crop, including self-propelled machinery:

- o Specifically designed or especially adapted for applying plant food materials or agricultural chemicals
- o Not designed or adapted for the sole purpose of transporting the materials or chemicals.

Examples of items considered implements of husbandry. Cultivators, farm tractors, reapers, binders, combines, cotton module builders, planters, disc subsoilers, tractors, dozers (when used to till the soil in a farming operation), sprayers, bailers, fertilizer spreaders, etc.

Examples of items not considered implements of husbandry. Automobiles, trucks, or items used on farms but that do not till the soil such as irrigation systems, silo barns, storage bins, cattle feeders, water tanks, etc.

The following table lists various scenarios and whether they require a permit, a bond, Texas Motor Carrier Registration or Unified Carrier Registration.

Fees. Implements of husbandry are eligible for single-trip and annual permits.

- Single-trip permit: \$60 + highway maintenance fees for 80,001 pounds or more.
- Annual implements of husbandry permit: \$270 + highway maintenance fee for 80,001 pounds or more.

Implements of husbandry requirements. The following table lists various scenarios and whether they require a permit, a bond, Motor Carrier Registration (MCR), or Unified Carrier Registration (UCR).

Load* Description	Specifications	Requirement	
		Permit	Bond MCR/UCR**
Over-length, hauled or moved by owner, agent or owner's employee	A vehicle or combination of vehicles used to transport a combine that is used in farm custom harvesting operations on a farm if the overall length of the vehicle or combination is not longer than 75 feet if traveling on the Interstate highway system, or not longer than 81 feet 6 inches if the vehicle is not traveling on the Interstate highway system	No	No*
Overwidth, moved by: • Owner • Agent • Owner's employee	<ul style="list-style-type: none"> • Overwidth only and being delivered to new owner • To transport to/from mechanic for repair/maintenance • In the course of an agricultural operation not to exceed 50 miles on Interstate highways 	No	No
Oversize/ overweight other than width	<ul style="list-style-type: none"> • To deliver to new owner • To transport to/from mechanic for repair/ maintenance • In the course of an agricultural operation regardless of miles traveled on the Interstate highways 	Yes	No
Oversize/ overweight moved by dealer or manufacturer	<ul style="list-style-type: none"> • To deliver to farmer • To bring back to place of business for repairs 	Yes	No
	To deliver to another dealer or manufacturer	Yes	Yes
Oversize/ overweight moved by a transporter (hauling for hire)	<ul style="list-style-type: none"> • To deliver to farmer • To bring back to place of business for repairs 	Yes	Yes
	To deliver to another dealer or manufacturer	Yes	Yes

* When the implement is not self-propelled and has to be moved by another vehicle, include the vehicle as part of the load.

** MCR is required for all loads that exceed 48,000 pounds.

Portable Building Units

(TRC §§ 623.121 - 623.130)

Portable building carriers are not required to have a moving authority or a superheavy or oversize permit bond when.

- The load dimensions do not exceed those allowed for a portable building permit

Definition. A portable building is a pre-fabricated structure and other components that are delivered by the manufacturer as a complete, inspected unit with a distinct serial number, whether fully assembled, partially assembled, or an unassembled kit, when loaded for transport.

Measurement requirements. A vehicle, or vehicle combination, transporting one or more portable building units that exceeds legal length or legal width limits are eligible for a portable building permit provided the combined measurements of the load and towing vehicle do not exceed the:

- Legal height of 14 feet
- Overall length of 80 feet with no more than a 4 foot overhang.

Applicants exceeding legal height (14 feet) and/or overall length (80 feet) must apply for a regular oversize permit and must adhere to the rules for such.

If the vehicle is transporting more than one portable building and the rear overhang exceeds 4 feet, a building must be removed.

Limitations. The maximum combined measurements of the load and towing vehicle must not exceed 14 feet in height or 80 feet in length.

Loading requirements. Portable buildings may be loaded end-to-end provided the overall length does not exceed 80 feet and/or 4 feet of rear overhang. Portable buildings may not be loaded side-by-side nor stacked if this causes the load to exceed legal width and or height.

Fee. Portable Building Permit: \$15.

Oil Well Servicing and Drilling Machinery

(TRC §§ 623.141 - 623.150)

Definition. Oil well servicing and drilling machinery are defined as those vehicles constructed as a machine used solely for servicing, cleaning out and/or drilling oil wells, and consisting in general of a mast, an engine for power, a draw works and chassis permanently constructed or assembled for such purpose(s).

Permits eligibility. Single-trip, single-trip (mileage), quarterly and annual oversize and overweight permits may be issued for the movement of oil well servicing and drilling machinery. The permits allow vehicle loads to exceed the legal width, height, length and weight limitations.

Limitations. The maximum weight for any single axle is not to exceed 30,000 pounds. Such weight shall not exceed 950 pounds per square inch of tire width for steerable axles.

Fees. Permit fees are as follows:

- Annual Oil Well Servicing Unit Permit: \$52 per axle
- Single-Trip, Single-Trip Mileage Permit and Quarterly Hubometer* Permit:
 - o \$31 minimum fee
 - o Mileage traveled multiplied by the fee determined by the width and the height measurements, in

addition to the weight in excess of legal on the axle/s group/s.

- * A hubometer is required on all vehicles issued a quarterly permit under this section.

Unladen Lift Equipment Motor Vehicles (Motor Cranes)

(TRC §§ 623.191 - 623.199)

Definition. An unladen lift equipment motor vehicle is a self-propelled unladen mobile crane constructed as a machine used solely for lifting purposes and consisting in general of a boom, an engine for power and a chassis permanently constructed or assembled for the purpose of lifting.

Registration. An unladen lift equipment motor vehicle can be registered with a regular commercial truck registration for the gross weight of the vehicle, or with permit or machinery plates.

Permits eligibility. Single-trip, single-trip mileage, quarterly and annual oversize/overweight permits may be issued for the movement of unladen lift equipment (mobile cranes).

The permit allows the vehicle to exceed the legal width, height, length, and weight limitations.

Limitations. The maximum weight for a single axle or any axle in an axle group may not exceed 30,000 pounds and the weight must not exceed 850 pounds per inch of tire width.

Fees. Permit fees are as follows:

- Annual Mobile Crane (Unladen Lift Equipment) Permit: \$100
- Single-Trip, Single-trip Mileage Permit and Quarterly Hubometer* Permit:
 - o \$31 minimum fee

- o Mileage traveled multiplied by the fee determined by the width and the height measurements, in addition to the weight in excess of legal on the axle/s group/s.
- * A hubometer is required on all vehicles issued a quarterly permit under this section.

Permits for Over Axle and Over Gross Weight Tolerances

Permit eligibility. *Texas Transportation Code (TRC), §623.011*, authorizes an annual weight tolerance permit to allow commercial motor vehicles (truck or truck-tractor in combination with trailer and/or semitrailer) to operate with weight that exceeds the allowable axle or gross weight for those vehicles.

This weight tolerance permit is issued only to the power unit.

Route restrictions. A permit issued under this section does not authorize the operation of a vehicle on:

- The national system of interstate and defense highways in the state (main lanes or frontage roads)
- A bridge for which a maximum weight and load limit has been established and posted if the gross weight of the vehicle and load or axles and wheel loads are greater than the limits established and posted.

Load-posted bridges. A vehicle moving with a weight tolerance permit may not travel over a load-posted bridge when exceeding the posted weight limits, unless the bridge provides the only public vehicular access to or from the permitted vehicle's origin or destination.

Vehicle transporting non-agricultural products. This permit authorizes the operation of a vehicle transporting non-agricultural products to travel on state maintained and county roads or counties selected on the permit with a tolerance of:

- Up to 10 percent above legal axle weight
- Up to, but not more than, five percent above gross vehicular weight.

Vehicle transporting agricultural products. Agricultural products include timber, pulp wood, wood chips, cotton, livestock, or agricultural products in their natural state that are being transported from the place of production to the place of first marketing or processing (*TRC §621.508*).

This permit authorizes the operation of a vehicle transporting agricultural products to travel on state maintained and county roads or counties selected on the permit with a tolerance of:

- Up to 12% above legal axle weight on one tandem, 10% on the rest not to exceed 84,000 pounds
- Up to, but not more than 5 percent above gross vehicular weight

Bond or irrevocable letter of credit. A bond or an irrevocable letter of credit for \$15,000 is required for vehicles hauling non-agricultural products. An applicant must file the bond payable to TxDOT. The Federal Deposit Insurance Corporation must guarantee deposits of financial institutions that issue letters of credit.

The bond is effective until the insurance or bonding company notifies TxDOT that the bond is no longer valid. For vehicles hauling agricultural products, a bond or letter of credit is not required.

Fees. A permit is valid for one year from the permit start date. The fee includes:

- \$75 base fee
- \$5 administrative fee
- fee, based to the following sliding fee scale

Fees Based on Number of Counties Traveled

Number of Counties on Permit Application	Fee
1-5	\$175
6-20	\$250
21-40	\$450
41-60	\$625
61-80	\$800
81-100	\$900
101-254	\$1,000

Motor carrier registration requirements. A commercial motor vehicle, or combination of vehicles, with a gross weight, registered weight, or gross weight rating exceeding 26,000 pounds must be registered with TxDMV as a motor carrier. For information and forms call 1-800/368-4689.

Vehicle registration. Registration must be for the maximum permissible weight for a particular vehicle, not to exceed 80,000 pounds. The permit does not increase the registered weight limit, but only allows a tolerance above the maximum registered weight.

When a semitrailer registered with a token plate or an apportioned trailer plate operates in combination with a Texas-registered truck-tractor operating with a permit, the semitrailer must increase the token fee from \$15 to \$30.

A vehicle registered in another state qualifies for a permit if it has apportioned registration and Texas is listed on its cab card. If a vehicle does not have apportioned

registration, full Texas registration is required. **TxDOT does not issue temporary vehicle registration to this type of vehicle.**

For more information on weight tolerance permits, see *43 Texas Administrative Code, Part 1, Chapter 28, Subchapter C.*

Port of Brownsville Port Authority Permits

The Brownsville Navigation District of Cameron County (Port of Brownsville), Texas, has special authority from the Department to issue permits for the movement of oversize or overweight vehicles carrying cargo on a designated corridor as set out in *Texas Transportation Code, Chapter 623, Subchapter K.*

The permit fee is \$30 per trip.

The Port of Brownsville specialized oversize/overweight permit allows for the movement of oversize or overweight vehicles carrying cargo on the following roads:

- State Highway 48/State Highway 4 between the Gateway International Bridge and the entrance to the Port of Brownsville
- or
- U.S. Highway 77/U.S. Highway 83 and State Highway 48/State Highway 4 between the Veterans International Bridge at Los Tomates and the entrance to the Port of Brownsville

The gross weight of cargo and equipment shall not exceed the allowable permissible axle load, the Mexican Legal Weight Limit, or 125,000 pounds, whichever is less, and the dimensions of the load and vehicle shall not exceed 12 feet wide, 15 feet 6 inches high, or 110 feet long.

Movement of a permitted vehicle is prohibited when visibility is reduced to less than 2/10 of one mile or the road surface is hazardous due to weather conditions such as rain, ice, sleet, or snow, or highway maintenance or construction work.

An oversize permitted vehicle may be moved only during daylight hours; however, an overweight only permitted vehicle may be moved at any time.

The Port of Brownsville has an online self-permitting system that allows for online payments, virtual cash receipts and permit-tracking. The system was designed to ensure permits are issued according to statute and existing administrative rules. The permit system is located at: <https://texas.promiles.com/Brownsville>.

Chambers County Permits

Chambers County, Texas, has special authority from the department to issue permits for the movement of oversize or overweight vehicles and loads on Farm-to-Market Road 1405 and the frontage road of State Highway 99 located in the Cedar Crossing Business Park as set out in *Texas Transportation Code, Chapter 623, Subchapter M*.

The gross weight of cargo and equipment shall not exceed the allowable permissible axle load, or 100,000 pounds, whichever is less and the dimensions of the load and vehicle shall not exceed 12 feet wide, 16 feet high, or 110 feet long.

Movement of a permitted vehicle is prohibited when visibility is reduced to less than 2/10 of one mile or the road surface is hazardous due to weather conditions such as rain, ice, sleet, or snow, or highway maintenance or construction work.

An oversize permitted vehicle may be moved only during daylight hours; however, an overweight only permitted vehicle may be moved at any time.

Chambers County has an online self-permitting system that allows for online payments, virtual cash receipts and permit-tracking. The system was designed to ensure permits are issued according to statute and existing administrative rules. The permit system is located at: <http://texas.promiles.com/chambers>.

Compliance

A person operating a vehicle for which a permit is required shall comply with all applicable terms, conditions and requirements of the permit and applicable rules and *TRC Chapters §§621, 622 or 623*.

A person operating on a public road or highway a vehicle for which a permit is not required shall comply with the weight and size provisions of *TRC Chapters §§621, 622 or 623*.

A person may not operate on a highway or public road a vehicle that exceeds its gross weight registration.

False information on the permit is considered a violation and subjects the permit to revocation and enforcement provisions set out in TAC Chapter §28.

Shipper's certificate of weight. When a shipper's certificate of weight is used, the shipper must certify that the information on the form is accurate and must deliver the form to the motor carrier or person before an overweight permit is applied for or before transportation of the shipment begins.

A motor carrier who holds an annual envelope permit may rely on the shipper's certificate of weight to determine whether the shipment requires an additional overweight permit.

A person may use the certificate of weight as a defense for not obtaining the required overweight permit.

Permit compliance. A permit issued under this chapter becomes invalid immediately on the violation of a rule or a condition or requirement placed on the permit. Any movement thereafter is a violation and subject to enforcement action under *TAC Chapter §28 and TRC Chapters §§621, 622 and 623*.

Records and Inspections

Persons and motor carriers subject to *Transportation Code, Chapters 621, 622 or 623*, are required to maintain certain information and records and provide access to any such records to department investigators for examining and inspecting these records.

All records and information required by the department shall maintain at the principal place of business for not less than two years. These records shall include:

- operational logs, insurance certificates and documents to verify the person's operations;
- complete and accurate records of services performed;
- all certificate of title documents, shipper's certificate of weight, including information used to support the shipper's certificate of weight, weight tickets, permits for oversize or overweight vehicles and loads, dispatch records, load tickets, waybill or any other document that verify the operations of the vehicle to determine the actual weight, insurance coverage, size or capacity of the vehicle, and the size or weight of the commodity being transported.

Copies of the oversize or overweight permit shall be maintained in the vehicle for which the permit was issued during the period that the permit is required. The permit shall be presented to a department inspector or any other authorized government personnel upon demand.

Inspections.

- A person shall give an inspector access to the person's premises to conduct inspections or investigations of an alleged violation of 43 *TAC Chapter 28, or Transportation Code, Chapters 621, 622 or 623*. The person shall provide adequate workspace with reasonable working conditions and shall allow the inspector to copy and verify records and documents.
- Inspections and investigations will be conducted during normal business hours unless mutual arrangements have been made otherwise.
- The inspector will present to the person the inspector's credentials and a written statement from the department indicating the inspector's authority to conduct the investigation.

Regional office or driver work-reporting location. All records and documents required by this subchapter which are maintained at the regional office or driver work-reporting location shall be made available for inspection upon request at the motor carrier's principal place of business or other location specified by the department within 48 hours after a request is made.

Enforcement

Administrative penalties. The department may impose an administrative penalty against a person who:

- Provides false information on a permit application
- Violates *Transportation Code, Chapters 621, 622 or 623* or any adopted orders of these chapters

- Fails to obtain an oversize overweight permit
- Violates an order adopted under TAC Chapter 28 or Transportation Code, Chapters 621, 622 or 628.

The amount of the penalty may not exceed \$5,000 per violation, unless it is found the person knowingly committed the violation at which time the penalty may not exceed \$15,000. If it is found that a person knowingly committed multiple violations, the penalty may be in an amount not to exceed \$30,000, based on the following factors:

- Seriousness of the violation
- Economic harm to property or the environment
- History of previous violations
- Amount necessary to deter future violations
- Efforts made to correct the violation and
- Other matters that justice may require.

Administrative sanctions. The department may revoke, suspend, or deny an oversize or overweight permit if the person

- Provides false information on a permit application
- Violates *Transportation Code, Chapters 621, 622 or 623* or any adopted orders of these chapters
- Fails to obtain an oversize overweight permit
- Violates an order adopted under *TAC Chapter 28 or Transportation Code 621, 622, 623.*

The department may probate a suspension upon review of

- Seriousness of the violation
- Prior violations
- Prior probated suspensions for the person
- Cooperation by the person in the investigation and enforcement proceeding; and
- Ability of the person to correct the violation.

The length of the probation will be based on the seriousness of the violation. During the probation, the

person will be required to report to the department on a monthly basis. The department may revoke the probation and impose a deferred administrative penalty if the person fails to abide by the terms of the probation.

Nonpayment of penalties. The department may not issue an oversize or overweight permit to the person who has not paid an administrative penalty that is due or for the vehicle that is the subject of the enforcement order until the amount of the delinquent administrative penalty has been paid to the department.

Proceedings. If the department decides to take an enforcement action under this subchapter, the department shall, in writing give notice to the person whom the action is being taken. That notice must include:

- Summary of alleged violation
- Statement of each enforcement action being taken
- Effective date of each enforcement action
- A statement informing a person of their rights to request a hearing
- A statement describing the procedure for requesting a hearing.
- A statement that the proposed penalties and sanctions will take effect on the date specified in the letter if the person fails to request a hearing.

The person must submit a written request for a hearing not later than the 26th day after the date the notice is mailed. On receipt of the written request, the department will refer to the State Office of Administrative Hearings. When the hearing is set, the department will notify the person of time and place of hearing. If the person does not make a written request for a hearing, or enter into a settlement agreement before the 27th day after the date that the notice is mailed, the department's decision becomes final and unappealable.

False information on certificate by shipper. The department may investigate and impose an administrative penalty on a shipper who provides false information on a shipper's certificate of weight. The amount of such penalty is calculated in the same manner as other administrative penalties.

Temporary Vehicle Registration

This subsection explains the types of temporary vehicle registration that allow temporary movement of unregistered vehicles under specific circumstances.

72-Hour and 144-Hour Temporary Vehicle Registration

A 72-hour or 144-hour permit can be issued to commercial vehicles when such vehicles are not authorized to operate on Texas highways due to lack of registration or lack of registration reciprocity.

A 72/144-hour temporary permit provides full temporary vehicle registration to a laden or unladen truck, truck-tractor, trailer, semitrailer and motor bus making the vehicle legal to travel in Texas. Applicants must provide proof of financial responsibility.

Example. If the vehicle is registered for 69,000 pounds gross weight, but has sufficient number of axles and axle spacings for the gross maximum allowable weight of 80,000 pounds, then the vehicle has not been registered for the maximum allowable weight and must purchase 72- or 144-hour temporary vehicle registration to increase the weight to 80,000 pounds.

Exceptions. A vehicle does not need an inspection sticker when the vehicle:

- Displays current out-of-state license plates
- Is a drilling and servicing vehicle used in the production of gas and crude petroleum oil.

Oil well servicing units and motor cranes registered out-of-state are considered commercial vehicles and must purchase 72/144-hour temporary vehicle registration. These types of vehicles normally cannot be apportioned.

If a truck or tractor is issued 72/144-hour temporary vehicle registration, any semitrailer operated in the combination must also be issued temporary vehicle registration, unless the vehicle is registered with current, regular Texas trailer license plates. Token trailer or apportioned license plates are not considered to be full or regular Texas registration and therefore, must purchase 72/144-hour temporary vehicle registration when pulled by a 72/144-hour temporary registered truck.

72/144-hour temporary vehicle registration cannot be issued to a vehicle apprehended by law enforcement officers for registration violations. These vehicles are required to obtain full Texas registration plus and pay penalties and/or fines.

Fees

- 72-Hour Permit: \$25
- 144-Hour Permit: \$50

Applicants must provide proof of financial responsibility.

One-Trip Temporary Vehicle Registration

Unladen vehicles needing to move temporarily on Texas highways are eligible for one-trip temporary vehicle registration. The route must either begin or end in Texas. These permits only allow the vehicle to travel from the point of origin to a point of destination and such intermediate points are set forth in the application. The intermediate points must be shown for the purpose of establishing a definite route. This permit is valid for 15 days.

Eligibility for one-trip temporary vehicle registration.

The following vehicles are eligible for one-trip temporary vehicle registration:

- Passenger car
- Travel trailer
- Truck or truck-tractor in combination with an unladen semitrailer (Both vehicles in the combination require temporary vehicle registration.)
- Truck with a camper unit mounted on it
- Charter bus from another state or country (The bus may carry property and passengers.)
- Mobile office that is completely empty of furniture.

Fee. One-Trip Temporary Vehicle Registration: \$5.
Applicants must provide proof of financial responsibility.

This page is intentionally blank.

Other Helpful Information

Motor Carrier Forms and Publications

Motor carrier forms and publications are located on the TxDMV Web site at www.txdmv.gov, select “Forms” under the “that you need” section.

Motor Carrier Important Notices and Rules/Regulations

Motor carrier important notices and rules and regulations are located on the TxDMV Web site at www.dmv.gov, select “Notices and Rules” under the “Motor Carriers” section.

Motor Carrier Safety

Motor carriers are required to follow specific safety regulations. A *Texas Motor Carrier's Guide to Highway Safety* is available on the Texas Department of Public Safety (DPS) Web site: www.txdps.state.tx.us, then search CVE for a listing of all DPS Commercial Vehicle Enforcement Information and publications. DPS is responsible for safety enforcement in Texas. For federal safety information and enforcement, visit the Federal Motor Carrier Safety Administration Web site at www.fmcsa.dot.gov/safety-security/sites/company-safety.htm.

Commercial Driver License

Most motor carrier drivers are required to have a Commercial Driver License (CDL). To determine if a driver is required to have a CDL, visit the DPS Web site at www.txdps.state.tx.us/cve/texaslaws.htm, then select, “Do I need a commercial driver license (CDL)?”

The *Texas Commercial Motor Vehicle Driver's Handbook* can also be found on the DPS Web site. At the DPS home page, select “TX Driver License” then “Publications, Handbooks and Forms.”

DPS, Motor Carrier Bureau Headquarters in Austin, can be contacted by calling 1-800/299-1700, options 6 or 7 or by visiting www.txdps.state.tx.us.

TxDOT Toll-Free Automated Telephone

TxDOT offers a toll-free number for contacting state and federal agencies regarding motor carrier compliance.

- Dial toll-free 1-800/299-1700 and press a menu option for a desired topic.

If you do not have a touch-tone phone or would like to speak to an operator, hold for assistance. Menu options may change without notice.

TxDOT Automated Telephone Menu

Topic	Options		
Texas Motor Carrier Applications and Forms	0		
Oversize/overweight permits or temporary tags	1		
Weight Tolerance, 30/60/90 day, Quarterly, and Annual Permits	1	1	
Weight Tolerance Permits	1	1	1
30/60/90 day overwidth or overlength permits, annual hay, vehicle specific envelope or utility pole permits	1	1	2
Quarterly self-propelled cranes and well servicing unit permits	1	1	3
Annual company specific envelope, annual manufactured housing, annual well servicing, mobile crane & annual implement of husbandry permits	1	1	4
Superheavy loads exceeding 254,300 pounds	1	2	
Route Inspections, loads exceeding 20 feet wide, or 18 feet 11 inches high, or 125 feet long or for house moves	1	3	
Remote Permit System questions or information	1	4	
Permit amendments, general permit information, fax permit applications, and internet permit application inquiries	1	5	
Permit Amendments	1	5	1
Questions concerning internet permit applications and general permit information	1	5	2
Questions concerning fax permit applications	1	5	3
For Financial Transaction Information	1	6	
PAC, FirstPay, and Credit Card Transactions	1	6	1

TxDOT Automated Telephone Menu (cont.)

Topic	Options		
Escrow Account Information	1	6	2
Cash, Check, or Money Order Transactions	1	6	3
To Apply for Oversize/Overweight Permits, Western Regional Multi-State Permits or Temporary Registration	1	7	
To apply for oversize/overweight permits or temporary registration	1	7	1
To apply for Western Regional multi-state permits	1	7	2
Motor Carrier, Unified Carrier Registration, Insurance information and Inquiries	2		
Inquiries or assistance with Texas size/weight rules and regulations, size/weight compliance and enforcement or the online complaint management system	3		
Apportioned Vehicle License Plate Registration under the International Registration Plan	4		
International Fuel Tax Agreement and Other Motor Fuel Tax Information	5		
Drivers License Information	6		
Motor Carrier Safety Regulations	7		
Make your selection based on the geographic area nearest to your location.			
Region 1 – Dallas, Tyler, Texarkana	7	1	
Region 2 – Houston, Beaumont, Lufkin	7	2	
Region 3 - Corpus Christi, Brownsville, Laredo, San Antonio	7	3	
Region 4 – Midland, Abilene, El Paso	7	4	
Region 5 – Lubbock, Amarillo, Wichita Falls	7	5	
Region 6 – Waco, Austin, Temple	7	6	
USDOT Numbers and Federal Motor Carrier Safety Administration	8		
Texas DOT Numbers	8	1	
USDOT Numbers or Federal Motor Carrier Safety Administration Questions	8	2	

Updated 8/2010

TxDOT District Offices

District	Location	Number
Abilene	4250 North Clack Abilene 79601	325/676-6901
Amarillo	5715 Canyon Drive Amarillo 79114	806/356-3201
Atlanta	701 East Main St. Atlanta 75551-2418	903/799-1220
Austin	7901 North I-35 Austin 78753	512/832-7022
Beaumont	8350 Eastex Freeway Beaumont 77708-1701	409/898-5731
Brownwood	2495 Highway 183 N. Brownwood 76802-3227	325/643-0411
Bryan	1300 N. Texas Ave. Bryan 77803-2760	979/778-9611
Childress	7599 U.S. 287 Childress 79201-9705	940/937-7145
Corpus Christi	1701 S. Padre Island Dr. Corpus Christi 78416	361/808-2220
Dallas	4777 East Hwy. 80 Mesquite 75150-6642	214/320-6110
El Paso	13301 Gateway Boulevard West El Paso 79928-5410	915/790-4203
Ft. Worth	2501 SW Loop 820 Ft. Worth 76133	817/370-6512
Houston	7600 Washington Ave. Houston 77007	713/802-5001
Laredo	1817 Bob Bullock Lp. Laredo 78043	956/712-7400
Lubbock	135 Slaton Road Lubbock 79404-5201	806/748-4420
Lufkin	1805 N. Timberland Dr. Lufkin 75901	936/634-4433

TxDOT District Offices (cont.)

District	Location	Number
Odessa	3901 E. U.S. Hwy. 80 Odessa 79761	432/498-4711
Paris	1365 N. Main St. Paris 75460-2697	903/737-9206
Pharr	600 W. U.S. Exp. 83 Pharr 78577-1231	956/702-6101
San Angelo	4502 Knickerbocker Rd. San Angelo 76904	325/944-1501
San Antonio	4615 NW Loop 410 San Antonio 78229-0928	210/615-5801
Tyler	2709 West Front Street Tyler 75702-7712	903/510-9220
Waco	100 South Loop Drive Waco 76704-2858	254/867-2701
Wichita Falls	1601 Southwest Pkwy. Wichita Falls 76302-4906	940/720-7790
Yoakum	403 Huck Street Yoakum 77995-2973	361/293-4332

Commonly Used Terms

144-hour temporary vehicle registration. Temporary vehicle registration authorizes a vehicle to operate at maximum legal weight on a state highway for a period not longer than 144 consecutive hours, as prescribed by TRC §502.352.

72-hour temporary vehicle registration. Temporary vehicle registration authorizes a vehicle to operate at maximum legal weight on a state highway for a period not longer than 72 consecutive hours, as prescribed by TRC §502.352.

Bill of lading. A document issued describing the kind and quantity of goods being shipped, the shipper, the consignee, the port of loading and discharge and the carrying vessel. In the case of household goods, this would be the moving services contract.

Cab card. General term with multiple meanings – Could refer to ‘Insurance Cab Card’ which lists vehicles registered as commercial motor carrier has registered under the Certificate of Registration number issued by TxDMV, Motor Carrier Division for intrastate operations. Could also refer to the document describing a vehicle that was issued apportioned license plates when operating in Interstate commerce. Additionally, it could refer to other papers required to be kept in cab of a truck.

DOT. This term has multiple meanings because it is not specific – When used, it most commonly is pertaining to the United States Department of Transportation (USDOT), Federal Motor Carrier Safety Administration (FMCSA) regulations regarding safety requirements of drivers and/or commercial motor vehicles. It could also refer to commercial motor carrier licensing agencies, such as USDOT, FMCSA, for interstate operations (shipment crossing state line), or Texas Department of Transportation (TxDOT) for intrastate operations (shipments with origin and destination within the borders of Texas).

Gross weight. Total weight of vehicle(s) and cargo.

Lading. Cargo; freight being transported.

Net weight. Weight of cargo or freight (gross weight less tare weight = net weight)

Nondivisible load. A load that cannot be reduced to a smaller dimension without compromising the integrity of

the load or requiring more than eight hours of work using appropriate equipment to dismantle.

Permit account card (PAC). A debit card that can only be used to purchase a permit or temporary vehicle registration and which is issued by a financial institution that is under contract with TxDOT and the Comptroller of Public Accounts.

Registration. In general terms, could pertain to motor carrier licensing; vehicle registration relating to titles and license plates, could be Federal, or could be a TxDMV motor carrier certificate of registration.

Shipper's certificate of weight. Form 2280 in which the shipper certifies to the maximum weight of the shipment being transported. You may obtain this form at www.txdot.gov, search "Motor Carrier Forms," select "Oversize/Overweight Load Permits," and then "Shipper Certificate of Weight."

Shipper. Person who consigns the movement of a shipment.

Stop in transit. A portion of the shipment that is either picked up at a location other than the origin or dropped off at a location other than the final destination.

Storage in transit. Shipment placed in storage on a temporary basis at the direction of the shipper. Transportation of the shipment has not been terminated.

Tare weight. Weight of a vehicle when it is empty.

Temporary vehicle registration. A 72-hour temporary vehicle registration, 144-hour temporary vehicle registration, or one-trip registration, as defined by TRC §502.352.

Truck. A motor vehicle designed, used, or maintained primarily for the transportation of property.

Truck-tractor. A motor vehicle designed or used primarily for drawing another vehicle: (A) that is not constructed to carry a load other than a part of the weight of the vehicle and load being drawn, or (B) that is engaged with a semitrailer in the transportation of automobiles or boats and that transports the automobiles or boats on part of the truck-tractor.

Waybill. A document issued by a carrier giving details and instruction relating to the shipment of a consignment of goods. Typically, it will show the names of the consignor and consignee, the point or origin of the consignment, its destination, route and method of shipment and the amount charged for carriage. Unlike a bill of lading, which includes much of the same information, a waybill is not a document of title.

Texas State Contacts

Agencies	Topics	Contact
<p>Texas Online A one-stop-shop for government interactions, saving time and effort by directing you in the right direction. Texas Online makes government accessible 24 hours a day, 7 days a week.”</p> <p>www.texas.gov</p>	<p>Driver’s License Vehicle Registration Taxes and more...</p>	<p>877/452-9060</p>

Texas State Contacts (cont.)

Agencies	Topics	Contact
<p>Texas Comptroller of Public Accounts Window on State Government</p> <p>www.window.state.tx.us</p> <p>Any Texas-based entity operating qualified motor vehicle(s) in two or more IFTA (International Fuel Tax Agreement) jurisdictions may obtain a Texas IFTA license in lieu of obtaining trip permits to satisfy their motor fuels tax obligations to other states. Texas must be your based jurisdiction.</p>	Motor fuels tax	(TX) 800/ 252-1383
	Fuel permits IFTA	800/252-1383
<p>Texas Department of Housing and Community Affairs</p> <p>www.tdhca.state.tx.us/mh.htm</p>	Manufactured housing regulation	800/500-7074 512/475-2200
<p>Texas Commission on Environmental Quality (TCEQ)</p> <p>www.tceq.state.tx.us</p>	Hazardous materials transport registration and reporting	512/239-6833
	Air Check Texas Repair and Replacement Assistance Program (financial assistance for qualified owners of vehicles that failed emissions test)	800/913-3321

Texas State Contacts (cont.)

Agencies	Topics	Contact
<p>Texas Department of Public Safety (DPS)</p> <p>www.txdps.state.tx.us</p> <p>Railroad Crossings Emergency Hotline. To report malfunctions of mechanical devices at railroad crossings or other types of situations that may require immediate attention including a vehicle that may be hung-up on the tracks call 1-800/772-7677. This hotline is manned 24 hours a day by the Texas Department of Public Safety. All railroad crossing locations equipped with mechanical devices have a sign attached identifying the location site. This location site number is required when reporting a malfunction. For reporting hazardous conditions including a vehicle hung-up on the tracks at a non-mechanical site, the hotline operator will need to know the exact location in relation to the state highway system. Report the highway number and mileage from a town. If possible give the name of the railroad company that is listed at the site, as this will give the operator the information needed to be able to contact the company that owns the rail line.</p>	Headquarters	512/424-2000
	Driver records	512/424-2600
	Commercial Vehicle Enforcement	To locate a CVE office www.txdprs.state.tx.us/lw/locate CVE
	License & weight service	512/873-3100
	Traffic law enforcement	512/424-2110
	Hazardous materials	512/424-2110
	Motor Carrier Bureau	512/424-2051 512/424-2052 Open Records: 512/424-2050 e-mail: pio@txdps.state.tx.us Fax: 512/ 424-2649
	Railroad crossings emergency	800/772-7677
	Emergency roadside assistance	800/525-5555
	Complaints	512/424-5020
	Open records	512/424-2050
	Vehicle inspection & emission	512/424-2770
	Commercial driver license	512/424-2879 512/424-5653
Safety hazardous materials	512/424-2051 512/424-2052	

Texas State Contacts (cont.)

Agencies	Topics	Contact
Texas Department of Transportation (TxDOT) www.txdot.gov	OS/OW load permits	512/465-3500 800/299-1700
	Texas Highways Magazine	800/839-4997
	Traffic operations/ crash records	512/486-5780
	Tourism	800/452-9292
	TTY (phone device for the deaf)	800/687-5288
Texas Department of Motor Vehicles (TxDMV) www.txdmv.gov	International Reciprocity Plan (IRP)	512/374-5250 800/299-1700, opt. 4
	Motor carriers & Vehicle Titles and Registration (license plates, liens, titles)	800/299-1700, opt. 4 or 512/465-7611
	Special plates	512/374-5010
	Certificates of title	512/465-7611
Texas Department of Licensing and Regulation www.license.state.tx.us/towing/ towing.htm	Vehicle storage facilities (VSF) and tow trucks	800/803-9202 512/463-6599 512/475-2871 (fax)
Texas Secretary of State www.sos.state.tx.us	Selecting a business structure	512/463-5555
Texas Department of Insurance www.tdi.state.tx.us	Consumer Helpline	800/252-3439
Railroad Commission of Texas www.rrc.state.tx.us	Liquid Petroleum Gas (LPG or LP-Gas) Propane, Propylene Normal Butane Isobutane Butylenes	Main 877/228-5740 Austin 512/463-7288

Updated 1/2010

Federal Contacts

Agencies	Topics	Contact
U.S. Department of Transportation www.dot.gov		202/366-4000
Federal Motor Carrier Safety Administration www.fmcsa.dot.gov	U.S. DOT Numbers Status of DOT Numbers Operation Authority Numbers Safety Ratings Insurance filings	800/832-5660
	Household Movers (interstate moves only)	888/DOT-SAFT 888/368-7238
	Licensing	202/366-9805
	Insurance	202/385-2423
Hazardous Materials Information Center (HMIC) www.phmsa.dot.gov/hazmat	Pipeline Hazardous materials Hazardous cargo routing Rules Registration	800/467-4922 202/366-4488
Washington D.C. Information Line		800/832-5660
Federal Highway Administration www.fhwa.dot.gov		Austin 512/536-5952
Internal Revenue Service (IRS) www.irs.gov	Heavy Vehicle Use Tax (HVUT) Form 2290	800/829-1040
Better Business Bureau www.welcome.bbb.org		

Updated 1/2010

This page is intentionally blank.