

TEXAS DEPARTMENT OF TRANSPORTATION

Oversize/Overweight Permit Rules and Regulations

43 Texas Administrative Code Chapter 28, Subchapters A-K

General Permits

Permits for Over Axle and Over Gross Weight Tolerances

Permits for Oversize and Overweight Oil Well Related Vehicles

Permits for Oversize and Overweight Unladen Lift Equipment Motor Vehicles

Highway Crossings by Oversize and Overweight Vehicles and Loads

Port of Brownsville Port Authority Permits

Chambers County Permits

Compliance

Records and Inspections

Enforcement



January 2011
Motor Carrier Division (MCD)
Austin, Texas

FOREWORD

The Texas Department of Transportation (TxDOT) is charged by the Texas Legislature with regulating the movement of oversize and overweight vehicles and loads on the Texas highway system, to ensure the safety of the traveling public and to protect the integrity of highways and bridges.

To accomplish this task, the department adopted the rules in this booklet to provide uniform regulation.

If you need more information or assistance, contact the department at:

Texas Department of Transportation
Motor Carrier Division - BC
125 E. 11th Street
Austin, Texas 78701-1483
1-800/299-1700
<http://www.txdot.gov>



Administrative rules are amended as needed to reflect legislative mandates and policy revisions. The information contained in this booklet is current at the time of publication.

This page intentionally left blank.

Table of Contents

SUBCHAPTER A – GENERAL PROVISIONS

RULE §28.1 Purpose and Scope	7
RULE §28.2 Definitions.....	7
RULE §28.3 Surety Bonds for Ready-mix Concrete Trucks, Concrete Pump Trucks, Vehicles Transporting Recyclable Materials, and Solid Waste Vehicles	12

SUBCHAPTER B – GENERAL PERMITS

RULE §28.10 Purpose and Scope	13
RULE §28.11 General Oversize/Overweight Permit Requirements and Procedures	13
RULE §28.12 Single-Trip Permits Issued Under Transportation Code, Chapter 623, Subchapter D.....	28
RULE §28.13 Time Permits	32
RULE §28.14 Manufactured Housing, and Industrialized Housing and Building Permits.....	39
RULE §28.15 Portable Building Unit Permits.....	41
RULE §28.16 Permits for Military and Governmental Agencies	43
RULE §28.17 Multi-state Permitting Agreements.....	43

SUBCHAPTER C – PERMITS FOR OVER AXLE AND OVER GROSS WEIGHT TOLERANCES

RULE §28.30 Permits for Over Axle and Over Gross Weight Tolerances	45
--	----

SUBCHAPTER D – PERMITS FOR OVERSIZE AND OVERWEIGHT OIL WELL RELATED VEHICLES

RULE §28.40 Purpose and Scope	49
RULE §28.41 General Requirements.....	49
RULE §28.42 Single-Trip Mileage Permits.....	50
Appendix A Maximum Permit Weight Table.....	53
Appendix B Maximum Permit Weight Formulas	54
RULE §28.43 Quarterly Hubometer Permits.....	55
RULE §28.44 Annual Permits	58
RULE §28.45 Permits for Vehicles Transporting Liquid Products Related to Oil Well Production	59

SUBCHAPTER E – PERMITS FOR OVERSIZE AND OVERWEIGHT UNLADEN LIFT EQUIPMENT MOTOR VEHICLES

RULE §28.60 Purpose and Scope	61
RULE §28.61 General Requirements for Permits for Oversize and Overweight Unladen Lift Equipment Motor Vehicles	61
RULE §28.62 Single Trip Mileage Permits	62
Appendix A Maximum Permit Weight Table.....	65
Appendix B Maximum Permit Weight Formulas	66
RULE §28.63 Quarterly Hubometer Permits.....	67
RULE §28.64 Annual Permits	70

SUBCHAPTER F – HIGHWAY CROSSINGS BY OVERSIZE AND OVERWEIGHT VEHICLES AND LOADS

RULE §28.80 Purpose.....	73
RULE §28.81 Surety Bond	73
RULE §28.82 Preparation of Contract.....	73

SUBCHAPTER G – PORT OF BROWNSVILLE PORT AUTHORITY PERMITS

RULE §28.90 Purpose.....	75
RULE §28.91 Responsibilities.....	75
RULE §28.92 Permit Issuance Requirements and Procedures.....	77

SUBCHAPTER H – CHAMBERS COUNTY PERMITS

RULE §28.100 Purpose.....	81
RULE §28.101 Responsibilities.....	81
RULE §28.102 Permit Issuance Requirements and Procedures..	82

SUBCHAPTER I – COMPLIANCE

RULE §28.110 Purpose.....	87
RULE §28.111 Applicability.....	87
RULE §28.112 Falsification of Information on Application and Permit.....	87
RULE §28.113 Shipper Certificate of Weight.....	87
RULE §28.114 Compliance with Remote Permit System	88
RULE §28.115 Permits Issued by Another State	88
RULE §28.116 Permit Compliance.....	88

SUBCHAPTER J – RECORDS AND INSPECTIONS

RULE §28.200 Purpose.....	89
RULE §28.201 Investigations and Inspections of Records.....	89
RULE §28.202 Records	90

SUBCHAPTER K – ENFORCEMENT

RULE §28.300 Purpose.....	91
RULE §28.301 Administrative Penalties.....	91

RULE §28.302 Administrative Sanctions..... **92**
RULE §28.303 Implications for Nonpayment of Penalties;
Grounds for Action **92**
RULE §28.304 Administrative Proceedings..... **93**
RULE §28.305 Settlement Agreements **93**
RULE §28.306 Administrative Penalty for False Information on
Certificate by a Shipper..... **94**

SUBCHAPTER A – GENERAL PROVISIONS

RULE §28.1 Purpose and Scope

The department is responsible for regulating the movement of oversize and overweight vehicles and loads on the state highway system, in order to insure the safety of the traveling public, and to protect the integrity of the highways and the bridges. This responsibility is accomplished through the issuance of permits for the movement of oversize and overweight vehicles and loads, and the execution of special contracts for the movement of oversize and overweight vehicles and loads to travel across the width of a state highway. The sections under this chapter prescribe the policies and procedures for the issuance of permits and the execution of contracts.

RULE §28.2 Definitions

The following words and terms, when used in this chapter, will have the following meanings, unless the context clearly indicates otherwise.

(1) **Annual permit**—A permit that authorizes movement of an overdimension load for one year commencing with the “movement to begin” date.

(2) **Applicant**—Any person, firm, or corporation requesting a permit.

(3) **Axle**—The common axis of rotation of one or more wheels whether power-driven or freely rotating, and whether in one or more segments.

(4) **Axle group**—An assemblage of two or more consecutive axles, with two or more wheels per axle, spaced at least 40 inches from center of axle to center of axle, equipped with a weight-equalizing suspension system that will not allow more than a 10% weight difference between any two axles in the group.

(5) **Cash collection office**—An office that has been designated as the place where a permit applicant can apply for a permit or pay for a permit with cash, cashier’s check, personal or business check, or money order.

(6) **Closeout**—The procedure used by the MCD to terminate a permit, issued under Transportation Code, §623.142 or §623.192 that will not be renewed by the applicant.

(7) **Commission**—The Texas Transportation Commission.

(8) **Complete identification number**—A unique and distinguishing number assigned to equipment or a commodity for purposes of identification.

(9) **Concrete pump truck**—A self propelled vehicle designed to pump the concrete product from a ready mix truck to the point of construction.

(10) **Crane**—Any unladen lift equipment motor vehicle designed for the sole purpose of raising, shifting, or lowering heavy weights by means of a projecting, swinging mast with an engine for power on a chassis permanently constructed or assembled for such purpose.

(11) **Credit card**—A credit card approved by the department and a permit account card.

(12) **Daylight**—The period beginning one-half hour before sunrise and ending one-half hour after sunset.

(13) **Department**—The Texas Department of Transportation.

(14) **Digital signature**—An electronic identifier intended by the person using it to have the same force and effect as a manual signature. The digital signature shall be unique to the person using it.

(15) **Director**—The Executive Director of the Texas Department of Transportation or a designee not below the level of division director.

(16) **District**—One of the 25 geographical areas, managed by a district engineer, in which the department conducts its primary work activities.

(17) **District engineer**—The chief executive officer in charge of a district of the department.

(18) **Electronic identifier**—A unique identifier which is distinctive to the person using it, is independently verifiable, is under the sole control of the person using it, and is transmitted in a manner that makes it infeasible to change the data in the communication or digital signature without invalidating the digital signature.

(19) **Escort vehicle**—A motor vehicle used to warn traffic of the presence of a permitted vehicle.

(20) **Foreign commercial vehicle annual registration**—An annual registration permit issued by the department to foreign commercial vehicles under authority of Transportation Code, §502.353.

(21) **Four-axle group**—Any four consecutive axles, having at least 40 inches from center of axle to center of axle, whose extreme centers are not more than 192 inches apart and are individually attached to or articulated from, or both, to the vehicle by a weight equalizing suspension system.

(22) **Gauge**—The transverse spacing distance between tires on an axle, expressed in feet and measured to the nearest inch, from center-of-tire to center-of-tire on an axle equipped with only two tires, or measured to the nearest inch from the center of the dual wheels on one side of the axle to the center of the dual wheels on the opposite side of the axle.

(23) **Gross weight**—The unladen weight of a vehicle or combination of vehicles plus the weight of the load being transported.

(24) **Height pole**—A device made of a non-conductive material, used to measure the height of overhead obstructions.

(25) **Highway maintenance fee**—A fee established by Transportation Code, §623.077, based on gross weight, and paid by the permittee when the permit is issued.

(26) **Highway use factor**—A mileage reduction figure used in the calculation of a permit fee for a permit issued under Transportation Code, §623.142 and §623.192.

(27) **Hubometer**—A mechanical device attached to an axle on a unit or a crane for recording mileage traveled.

(28) **HUD number**—A unique number assigned to a manufactured home by the U.S. Department of Housing and Urban Development.

(29) **Indirect cost share**—A prorated share of administering department activities, other than the direct cost of the activities, including the cost of providing statewide support services.

(30) **Load-restricted bridge**—A bridge that is restricted by the commission, under the provisions of Transportation Code, §621.102, to a weight limit less than the maximum amount allowed by Transportation Code, §621.101.

(31) **Load-restricted road**—A road that is restricted by the commission, under the provisions of Transportation Code, §621.102, to a weight limit less than the maximum amount allowed by Transportation Code, §621.101.

(32) **Machinery plate**—A license plate issued under Transportation Code, §504.504.

(33) **Manufactured home**—Manufactured housing, as defined in Occupations Code, Chapter 1201, and industrialized housing and buildings, as defined in Occupations Code, §1202.002, and temporary chassis systems, and returnable undercarriages used for the transportation of manufactured housing and industrialized housing and buildings, and a transportable section which is transported on a chassis system or returnable undercarriage that is constructed so that it cannot, without dismantling or destruction, be transported within legal size limits for motor vehicles.

(34) **Motor carrier**—A person that controls, operates, or directs the operation of one or more vehicles that transport persons or cargo over a public highway in this state, as defined in §18.2 of this title (relating to Definitions).

(35) **Motor Carrier Division (MCD)**—The Motor Carrier Division of the department.

(36) **Motor carrier registration (MCR)**—The registration issued by the department to motor carriers moving intrastate, under authority of Transportation Code, Chapter 643 as amended.

(37) **Nighttime**—The period beginning one-half hour after sunset and ending one-half hour before sunrise, as defined by Transportation Code, §541.401.

(38) **Nondivisible load**—A load that cannot be reduced to a smaller dimension without compromising the integrity of the load or requiring more than eight hours of work using appropriate equipment to dismantle.

(39) **Oil field rig-up truck**—An unladen vehicle with an overweight single steering axle, equipped with a winch and set of gin poles used for lifting, erecting, and moving oil well equipment and machinery.

(40) **Oil well servicing unit**—An oil well clean-out unit, oil well drilling unit, or oil well swabbing unit, which is mobile equipment, either self-propelled or trailer-mounted, constructed as a machine used solely for cleaning-out, drilling, servicing, or swabbing oil wells, and consisting in general of, but not limited to, a mast, an engine for power, a draw works, and a chassis permanently constructed or assembled for this purpose.

(41) **One trip registration**—Temporary vehicle registration issued under Transportation Code, §502.354.

(42) **Overdimension load**—A vehicle, combination of vehicles, or vehicle and its load that exceeds maximum legal width, height, length, overhang, or weight as set forth by Transportation Code, Chapter 621, Subchapters B and C.

(43) **Overhang**—The portion of a load extending beyond the front or rear of a vehicle or combination of vehicles.

(44) **Overheight**—An overdimension load that exceeds the maximum height specified in Transportation Code, §621.207.

(45) **Overlength**—An overdimension load that exceeds the maximum length specified in Transportation Code, §621.203, §621.204, §621.205, and §621.206.

(46) **Overweight**—An overdimension load that exceeds the maximum weight specified in Transportation Code, §621.101.

(47) **Overwidth**—An overdimension load that exceeds the maximum width specified in Transportation Code, §621.201.

(48) **Permit**—Authority for the movement of an overdimension load, issued by the MCD under Transportation Code, Chapter 623.

(49) **Permit account card (PAC)**—A debit card that can only be used to purchase a permit or temporary vehicle registration and which is issued by a financial institution that is under contract to the department and the Comptroller of Public Accounts.

(50) **Permit officer**—An employee of the MCD who is authorized to issue an oversize/overweight permit or temporary vehicle registration.

(51) **Permit plate**—A license plate issued under Transportation Code, §504.504, to a crane or an oil well servicing vehicle.

(52) **Permitted vehicle**—A vehicle, combination of vehicles, or vehicle and its load operating under the provisions of a permit.

(53) **Permittee**—Any person, firm, or corporation that is issued an oversize/overweight permit or temporary vehicle registration by the MCD.

(54) **Pipe box**—A container specifically constructed to safely transport and handle oil field drill pipe and drill collars.

(55) **Portable building compatible cargo**—Cargo, other than a portable building unit, that is manufactured, assembled, or distributed by a portable building unit manufacturer and is transported in combination with a portable building unit.

(56) **Portable building unit**—The pre-fabricated structural and other components incorporated and delivered by the manufacturer as a complete inspected unit with a distinct serial number whether in fully assembled, partially assembled, or kit (unassembled) configuration when loaded for transport.

(57) **Principal**—The person, firm, or corporation that is insured by a surety bond company.

(58) **Recyclable materials**—Material that has been recovered or diverted from the solid waste stream for purposes of reuse, recycling, or reclamation, a substantial portion of which is consistently used in the manufacture of products which may otherwise be produced using raw or virgin materials. Recycled

material is not solid waste unless the material is deemed to be hazardous solid waste by the Administrator of the United States Environmental Protection Agency, whereupon it shall be regulated accordingly unless it is otherwise exempted in whole or in part from regulation under the federal Solid Waste Disposal Act, as amended by the Resource Conservation and Recovery Act of 1976 (42 U.S.C. Section 6901 et seq.), by Environmental Protection Agency regulation. However, recyclable material may become solid waste at such time, if any, as it is abandoned or disposed of rather than recycled, whereupon it will be solid waste with respect only to the party actually abandoning or disposing of the material.

(59) **Registration reduction**—A 25% reduction of the permit fee that applies to a crane or oil well servicing unit registered for maximum legal weight.

(60) **Shipper**—Person who consigns the movement of a shipment.

(61) **Shipper's certificate of weight**—A form approved by the department in which the shipper certifies to the maximum weight of the shipment being transported.

(62) **Single axle**—An assembly of two or more wheels whose centers are in one transverse vertical plane or may be included between two parallel transverse planes 40 inches apart extending across the full width of the vehicle.

(63) **Single state registration (SSR)**—Interstate registration authority issued to motor carriers under authority of 49 U.S.C. §14504 and Transportation Code, Chapter 645.

(64) **Single-trip permit**—A permit issued for an overdimension load for a single continuous movement over a specific route for an amount of time necessary to make the movement.

(65) **State highway**—A highway or road under the jurisdiction of the Texas Department of Transportation.

(66) **State highway system**—A network of roads and highways as defined by Transportation Code, §221.001.

(67) **Surety bond**—An agreement issued by a surety bond company to a principal that pledges to compensate the department for any damage that might be sustained to the highways and bridges by virtue of the operation of the equipment for which a permit was issued. A surety bond is effective the day it is issued and expires at the end of the state fiscal year, which is August 31st. For example, if you obtain a surety bond on August 30th, it will expire the next day at midnight.

(68) **Tare weight**—The empty weight of any vehicle transporting an overdimension load.

(69) **Temporary vehicle registration**—A 72-hour temporary vehicle registration, 144-hour temporary vehicle registration, or one-trip registration, as defined by Transportation Code, §502.352.

RULE §28.3 Surety Bonds for Ready-mix Concrete Trucks, Concrete Pump Trucks, Vehicles Transporting Recyclable Materials, and Solid Waste Vehicles

(a) Surety bond required. A surety bond is required for:

(1) ready-mixed concrete trucks and concrete pump trucks operated under the provisions of Transportation Code, §622.013;

(2) vehicles used exclusively to transport recyclable materials operated under the provisions of Transportation Code, §622.134; and

(3) vehicles used exclusively to transport solid waste under the provisions of Transportation Code, §623.163.

(b) Surety bonds.

(1) Surety bonds filed under this section must:

(A) be in the amount of \$1,000 per vehicle (for example, if 10 trucks are covered by the surety bond then the total amount of the surety bond would be \$10,000);

(B) indicate the total amount of coverage; and

(C) be submitted in duplicate to the MCD on Form 1382 or Form 1575.

(D) A surety bond is effective the day it is issued and expires at the end of the state fiscal year, which is August 31st. For example, if you obtain a surety bond on August 30th, it will expire the next day at midnight.

(2) Form 1382-A or Form 1576 must be completed in duplicate and submitted to the MCD for certification of each vehicle bonded under Forms 1382 or Form 1575.

(A) The MCD will certify and return to the principal, one copy of Form 1382 or Form 1575, and one copy of Form 1382-A or Form 1576.

(B) The original Form 1382-A or Form 1576 must be carried in the cab of the bonded vehicle.

(3) Form 1383 or Form 1577 must be used to add or delete a vehicle covered by Form 1382 or Form 1575, and must be completed in duplicate and submitted to the MCD for certification.

(A) The MCD will certify and return to the principal, one copy of Form 1383 or Form 1577 when a new vehicle is added to the surety bond. When a vehicle is dropped from the surety bond the MCD will make the necessary revision to the principal's file.

(B) Form 1383 or Form 1577 must be carried in the cab of the bonded vehicle.

(4) A facsimile copy of Forms 1382, 1382-A, 1383, 1575, 1576 or 1577 is not acceptable in lieu of the original surety bond.

SUBCHAPTER B – GENERAL PERMITS

RULE §28.10 Purpose and Scope

(a) In accordance with Transportation Code, Chapters 621, 622, and 623, the department may issue permits for the operation of oversize and/or overweight vehicles for:

(1) the transportation of cargo that cannot be reasonably dismantled when the size or gross weight exceeds the limits allowed by law;

(2) the transportation of oversize portable building units and portable building compatible cargo;

(3) the movement of oversize manufactured housing and industrialized buildings;

(4) the movement of cylindrically shaped bales of hay; and

(5) the movement of water well drilling machinery and equipment.

(b) The issuance of a permit for an oversize and/or overweight unit is not a guarantee by the department that the highways can safely accommodate such movement. The transporter of a unit is responsible for any damage caused to the state highway system or any of its structures or appurtenances by movement of the unit, whether or not the unit is permitted.

(c) The following sections in this subchapter set forth the requirements and procedures applicable to those permits.

RULE §28.11 General Oversize/Overweight Permit Requirements and Procedures

(a) Purpose and scope. This section contains general requirements relating to oversize/overweight permits, including single trip permits. Specific requirements for each type of specialty permit are provided for in this chapter.

(b) Prerequisites to obtaining an oversize/overweight permit. Unless exempted by law or this chapter, the following requirements must be met prior to the issuance of an oversize/overweight permit.

(1) Commercial motor carrier registration or surety bond. Prior to obtaining an oversize/overweight permit, an applicant permitted under the provisions of Transportation Code, Chapter 623, Subchapter D, must be registered as a commercial motor carrier under Chapter 18 of this title (relating to Motor Carriers) or, if not required to obtain a motor carrier registration, file a surety bond with the department as described in subsection (n) of this section.

(2) Vehicle registration. A vehicle registered with a permit plate will not be issued an oversize/overweight permit under this subchapter. A permitted vehicle operating under this subchapter must be registered with one of the following types of vehicle registration:

(A) current Texas license plates that indicate the permitted vehicle is registered for maximum legal gross weight or the maximum weight the vehicle can transport;

(B) Texas temporary vehicle registration;
(C) current out of state license plates that are apportioned for travel in Texas; or
(D) foreign commercial vehicles registered under Texas annual registration.

(c) Permit application.

(1) An application for a permit may be made to the MCD by telephone, by facsimile, electronically, or in person at a cash collection office. All applications shall be made on a form prescribed by the department, and all applicable information shall be provided by the applicant, including:

(A) name, address, and telephone number of applicant;
(B) applicant's customer identification number;
(C) applicant's motor carrier registration number or single state registration number, if applicable;
(D) complete load description, including maximum width, height, length, overhang, and gross weight;
(E) complete description of equipment, including truck make, license plate number and state of issuance, and vehicle identification number, if required;

(F) equipment axle and tire information including number of axles, distance between axles, axle weights, number of tires, and tire size for overweight permit applications; and

(G) any other information required by law.

(2) Applications transmitted electronically are considered signed if a digital signature is transmitted with the application and intended by the applicant to authenticate the application.

(A) The department may only accept a digital signature used to authenticate an application under procedures that comply with any applicable rules adopted by the Department of Information Resources regarding department use or acceptance of a digital signature.

(B) The department may only accept a digital signature to authenticate an application if the digital signature is:

(i) unique to the person using it;
(ii) capable of independent verification;
(iii) under the sole control of the person using it; and
(iv) transmitted in a manner that will make it infeasible to change the data in the communication or digital signature without invalidating the digital signature.

(3) All permit applications shall be accompanied by the appropriate fees described in this paragraph, in a payment method described in subsection (f) of this section.

(A) The fee for a single trip (not exceeding 80,000 pounds) permit is \$60. Fees for other types of permits are indicated in the appropriate subchapters of this chapter.

(B) Highway maintenance fees are as indicated in the following table, and are in addition to the permit fee.

Figure: 43 TAC §28.11(c)(3)(B)

Gross weight in pounds	Highway Maintenance Fee
80,001-120,000	\$150
120,001-160,000	\$225
160,001-200,000	\$300
200,001-above	\$375

(C) Vehicle supervision fees are as indicated in the following table, and are in addition to the permit fee and the highway maintenance fee.

Figure: 43 TAC §28.11(c)(3)(C)

Criteria	Vehicle Supervision Fee
200,001 - 254,300 pounds total and at least 95 feet over all axle spacings and not exceeding the maximum permissible weight on any axle or axle group, as described in subsection (d) of this section.	\$35
200,001 - 254,300 pounds total with less than 95 feet overall axle spacings, or is over the maximum permissible weight on any axle or axle group, or is over 254,300 pounds gross weight	\$500;
	\$35 for an additional identical load to be moved over the same route within 30 days of the movement date of the original permit;
	\$100 if no bridges are crossed.

(4) The MCD is closed on:

- (A) Sundays;
- (B) New Year's Day;
- (C) Memorial Day;
- (D) Independence Day;
- (E) Labor Day;
- (F) Thanksgiving Day and the Friday following Thanksgiving Day;

(G) Christmas Eve and Christmas Day;

(H) the Saturday prior to any of the holidays listed in this paragraph falling on a Sunday or a Monday, except the Saturday before Christmas Eve when Christmas Eve falls on a Monday;

(I) the Saturday after any of the holidays listed in this paragraph falling on a Friday, except for the Saturday following Thanksgiving Day and the Saturday following Christmas Day when Christmas Day falls on a Friday; and

(J) at other times as deemed necessary by the department's administration, such as in the case of emergency weather conditions.

(5) The MCD shall be open for the issuance of permits from 6:00 a.m. until 6:00 p.m. (Central Standard Time) Monday through Friday, and from 6:00 a.m. until 2:00 p.m. (Central Standard Time) on Saturdays.

(d) Maximum permit weight limits.

(1) General. An overweight permitted vehicle will not be routed over a load restricted bridge when exceeding the posted capacity of the bridge, unless a special exception is granted by the MCD, based on an analysis of the bridge.

(A) An axle group must have a minimum spacing of four feet, measured from center of axle to center of axle, between each axle in the group to achieve the maximum permit weight for the group.

(B) The maximum permit weight for an axle group with spacings of five or more feet between each axle will be based on an engineering study conducted by the MCD.

(C) A permitted vehicle will be allowed to have air suspension, hydraulic suspension and mechanical suspension axles in a common weight equalizing suspension system for any axle group.

(D) The MCD may permit axle weights greater than those specified in this section, for a specific individual permit request, based on an engineering study of the route and hauling equipment.

(E) An overdimensional load may not exceed the manufacturer's rated tire carrying capacity.

(F) Two or more consecutive axle groups having an axle spacing of less than 12 feet, measured from the center of the last axle of the preceding group to the center of the first axle of the following group, will be reduced by 2.5% for each foot less than 12 feet.

(2) Maximum axle weight limits. Maximum permit weight for an axle or axle group is based on 650 pounds per inch of tire width or the following axle or axle group weights, whichever is the lesser amount:

(A) single axle—25,000 pounds;

(B) two axle group—46,000 pounds;

(C) three axle group—60,000 pounds;

(D) four axle group—70,000 pounds;

(E) five axle group—81,400 pounds;

(F) axle group with six or more axles—determined by the MCD based on an engineering study of the equipment, which will include the type of

steering system used, the type of axle suspension, the spacing distance between each axle, the number of tires per axle, and the tire size on each axle; or

- (G) trunnion axles—60,000 pounds if;
 - (i) the trunnion configuration has two axles;
 - (ii) there are a total of 16 tires for a trunnion configuration; and
 - (iii) the trunnion axle as shown in the following diagram is 10 feet in width.

Figure: 43 TAC §28.11(d)(2)(G)(iii)

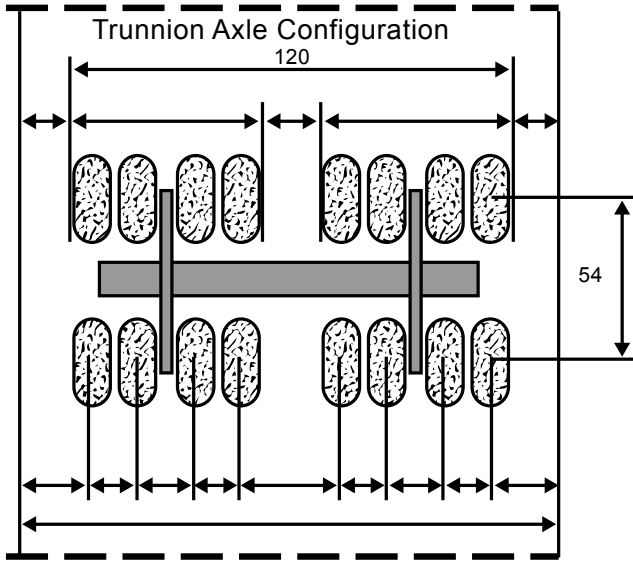

(3) Weight limits for load restricted roads. Maximum permit weight for an axle or axle group, when traveling on a load restricted road, will be based on 650 pounds per inch of tire width or the following axle or axle group weights, whichever is the lesser amount:

- (A) single axle—22,500 pounds;
- (B) two axle group—41,400 pounds;
- (C) three axle group—54,000 pounds;
- (D) four axle group—63,000 pounds;
- (E) five axle group—73,260 pounds;
- (F) axle group with six or more axles—determined by the MCD

based on an engineering study of the equipment, which will include the type of steering system used, the type of axle suspension, the spacing distance between each axle, the number of tires per axle, and the tire size on each axle;

(G) trunnion axles—54,000 pounds; and

(H) two or more consecutive axle groups having an axle spacing of less than 12 feet, measured from the center of the last axle of the preceding

group to the center of the first axle of the following group will be reduced by 2.5% for each foot less than 12 feet.

(e) Permit issuance.

(1) General. Upon receiving an application, the MCD will review the permit application for the appropriate information and will then determine the most practical route. After a route is selected and a permit number is assigned by the MCD, an applicant requesting a permit by telephone must legibly enter all necessary information on the permit application, including the approved route and permit number. Permit requests made by methods other than telephone will be returned via facsimile, mail, or electronically.

(2) Routing.

(A) A permitted vehicle will be routed over the most practical route available taking into consideration:

(i) the size and weight of the overdimension load in relation to vertical clearances, width restrictions, steep grades, and weak or load restricted bridges;

(ii) the geometrics of the roadway in comparison to the overdimension load;

(iii) sections of highways restricted to specific load sizes and weights due to construction, maintenance, and hazardous conditions;

(iv) traffic conditions, including traffic volume;

(v) route designations by municipalities in accordance with Transportation Code, §623.072;

(vi) load restricted roads; and

(vii) other considerations for the safe transportation of the load.

(B) When a permit applicant desires a route other than the most practical, more than one permit will be required for the trip unless an exception is granted by the MCD.

(3) Return movements. A permitted vehicle will be allowed return movement of oversize and overweight hauling equipment to the permitted vehicle's point of origin or the permittee's place of business, and may transport a non-divisible load of legal dimensions on the return trip, provided the transport is completed within the time period stated on the permit.

(4) Records retention.

(A) The original permit, a facsimile copy of the permit, or a MCD computer generated permit must be kept in the permitted vehicle until the day after the date the permit expires.

(B) All telephone requests for permits are recorded and retained for future reference.

(C) Permit information shall be stored in the department's mainframe computer located in Austin, which shall constitute the official permit record.

(f) Payment of permit fees, refunds.

(1) Payment methods. All permit applications must be accompanied by the proper fee, which shall be payable as described in this subsection.

(A) Credit card. A permit may be purchased with a valid credit card approved by the department. Credit card payments are subject to a \$1 fee per transaction in addition to the applicable permit fee.

(B) Permit Account Card (PAC)

(i) Application for a PAC should be made directly to the issuing institution. A PAC must be established and maintained according to the contract provisions stipulated between the PAC holder and the financial institution under contract to the department and the Comptroller of Public Accounts.

(ii) An applicant purchasing a permit with a PAC is subject to a \$1.00 fee per transaction in addition to the applicable permit fee.

(C) Checks, money orders, cashier's checks, or cash. Checks, money orders, cashier's checks, and cash are acceptable forms of payment for a permit. When ordering a permit by telephone, facsimile, or electronically, such payments shall be made at a cash collection office prior to obtaining the permit. Checks, money orders, and cashier's checks may also accompany applications made by mail.

(D) Escrow accounts. A permit applicant may establish an escrow account with the department for the specific purpose of paying any fee that is related to the issuance of a permit under this subchapter. An escrow account may also be utilized to pay fees related to the issuance of a vehicle storage facility license or a motor carrier registration issued under Chapter 18 of this title (relating to Motor Carriers).

(i) A permit applicant who desires to establish an escrow account shall complete and sign an escrow account agreement, and shall return the completed and signed agreement to the department with a check in the minimum amount of \$305, which shall be deposited to the appropriate fund by the department with the Comptroller of Public Accounts. In lieu of submitting a check for the initial deposit to an applicant's escrow account, the applicant may transfer funds to the department electronically.

(ii) Upon initial deposit, and each subsequent deposit made by the escrow account holder, \$5.00 will be charged as an escrow account administrative fee and shall be deposited in the state highway fund.

(iii) The escrow account holder is responsible for monitoring of the escrow account balance.

(iv) An escrow account holder must submit a written request to the department to terminate the escrow account agreement. Any remaining balance will be returned to the escrow account holder.

(2) Refunds. A permit fee will not be refunded after the permit number has been issued unless such refund is necessary to correct an error made by the permit officer.

(g) Amendments. A permit may be amended for the following reasons:

(1) vehicle breakdown;

(2) changing the intermediate points in an approved permit route;

(3) extending the expiration date due to conditions which would cause the move to be delayed;

(4) changing route origin or route destination prior to the start date as listed on the permit;

(5) changing vehicle size limits prior to the permit start date as listed on the permit, provided that changing the vehicle size limit does not necessitate a change in the approved route; and

(6) correcting any mistake that is made due to permit officer error.

(h) Requirements for overwidth loads.

(1) An overwidth load must travel in the outside traffic lane on multi-lane highways, when the width of the load exceeds 12 feet.

(2) Overwidth loads are subject to the escort requirements of subsection (k) of this section.

(3) A permitted vehicle exceeding 16 feet in width will not be routed on the main lanes of a controlled access highway, unless an exception is granted by the MCD, based on a route and traffic study. The load may be permitted on the frontage roads when available, if the movement will not pose a safety hazard to other highway users.

(4) An applicant requesting a permit to move a load exceeding 20 feet wide will be furnished with a proposed route. The applicant must physically inspect the proposed route to determine if the overdimension load can safely negotiate it, unless an exception is granted based on a route and traffic study conducted by the MCD. A permit application and the appropriate fee are required for every route inspection.

(A) The applicant must notify the MCD in writing whether the overdimension load can or cannot safely negotiate the proposed route.

(B) If any section of the proposed route is unacceptable, the applicant shall provide the MCD with an alternate route around the unacceptable section.

(C) Once a route is decided upon and a permit issued, the permit may not be amended unless an exception is granted by the MCD.

(i) Requirements for overlength loads.

(1) Overlength loads are subject to the escort requirements stated in subsection (k) of this section.

(2) A single vehicle, such as a motor crane, that has a permanently mounted boom is not considered as having either front or rear overhang as a result of the boom because the boom is an integral part of the vehicle.

(3) When a single vehicle with a permanently attached boom exceeds the maximum legal length of 45 feet, a permit will not be issued if the boom projects more than 25 feet beyond the front bumper of the vehicle, or when the boom projects more than 30 feet beyond the rear bumper of the vehicle, unless an exception is granted by the MCD, based on a route and traffic study.

(4) Maximum permit length for a single vehicle is 75 feet.

(5) A load extending more than 20 feet beyond the front or rearmost portion of the load carrying surface of the permitted vehicle must have a rear escort, unless an exception is granted by the MCD, based on a route and traffic study.

(6) A permit will not be issued for an overdimension load with:

(A) more than 25 feet front overhang; or

(B) more than 30 feet rear overhang, unless an exception is granted by the MCD, based on a route and traffic study.

(7) An applicant requesting a permit to move an overdimension load exceeding 125 feet overall length will be furnished with a proposed route. The applicant must physically inspect the proposed route to determine if the overdimension load can safely negotiate it, unless an exception is granted based on a route and traffic study conducted by the MCD. A permit application and the appropriate fee are required for every route inspection.

(A) The applicant must notify the MCD in writing whether the overdimension load can or cannot safely negotiate the proposed route.

(B) If any section of the proposed route is unacceptable, the applicant shall provide the MCD with an alternate route around the unacceptable section.

(C) Once a route is decided upon and a permit issued, the permit may not be amended unless an exception is granted by the MCD.

(8) A permitted vehicle that is not overwidth or overheight, and does not exceed 150 feet overall length, may be moved in a convoy consisting of not more than four overlength permitted vehicles. A permitted vehicle that is not overwidth or overheight that exceeds 150 feet, but does not exceed 180 feet overall length, may be moved in a convoy consisting of not more than two overlength permitted vehicles. Convoys are subject to the requirements of subsection (k) of this section. Each permitted vehicle in the convoy must:

(A) be spaced at least 1,000 feet, but not more than 2,000 feet, from any other permitted vehicle in the convoy; and

(B) have a rotating amber beacon or an amber pulsating light, not less than eight inches in diameter, mounted at the rear top of the load being transported.

(j) Requirements for overheight loads.

(1) Overheight loads are subject to the escort requirements stated in subsection (k) of this section.

(2) An applicant requesting a permit to move an overdimension load with an overall height of 19 feet or greater will be furnished with a proposed route. The applicant must physically inspect the proposed route to determine if the overdimension load can safely negotiate it, unless an exception is granted based on a route and traffic study conducted by the MCD. A permit application and the appropriate fee are required for every route inspection.

(A) The applicant must notify the MCD in writing whether the overdimension load can or cannot safely negotiate the proposed route.

(B) If any section of the proposed route is unacceptable, the applicant shall provide the MCD with an alternate route around the unacceptable section.

(C) Once a route is decided upon and a permit issued, the permit may not be amended unless an exception is granted by the MCD.

(k) Escort vehicle requirements. Escort vehicle requirements are provided to facilitate the safe movement of permitted vehicles and to protect the traveling public during the movement of permitted vehicles. A permittee must provide for escort vehicles and law enforcement assistance when required by the MCD. The requirements in this subsection do not apply to the movement of manufactured housing, portable building units, or portable building compatible cargo. Escort vehicle requirements for the movement of manufactured housing are described in §28.14 of this subchapter (relating to Manufactured Housing, and Industrialized Housing and Building Permits). Escort vehicle requirements for the movement of portable building units and portable building compatible cargo are described in §28.15 of this subchapter (relating to Portable Building Unit Permits).

(1) General.

(A) Applicability. The operator of an escort vehicle shall, consistent with applicable law, warn the traveling public when:

- (i) a permitted vehicle must travel over the center line of a narrow bridge or roadway;
- (ii) a permitted vehicle makes any turning movement that will require the permitted vehicle to travel in the opposing traffic lanes;
- (iii) a permitted vehicle reduces speed to cross under a low overhead obstruction or over a bridge;
- (iv) a permitted vehicle creates an abnormal and unusual traffic flow pattern; or
- (v) in the opinion of MCD, warning is required to ensure the safety of the traveling public or safe movement of the permitted vehicle.

(B) Law enforcement assistance. Law enforcement assistance may be required by the MCD to control traffic when a permitted vehicle is being moved within the corporate limits of a city, or at such times when law enforcement assistance would provide for the safe movement of the permitted vehicle and the traveling public.

(C) Obstructions. It is the responsibility of the permittee to contact utility companies, telephone companies, television cable companies, or other entities as they may require, when it is necessary to raise or lower any overhead wire, traffic signal, street light, television cable, sign, or other overhead obstruction. The permittee is responsible for providing the appropriate advance notice as required by each entity.

(2) Escort requirements for overwidth loads. Unless an exception is granted by the MCD, based on a route and traffic study, an overwidth load must:

(A) have a front escort vehicle if the width of the load exceeds 14 feet, but does not exceed 16 feet, when traveling on a two lane roadway;

(B) have a rear escort vehicle if the width of the load exceeds 14 feet, but does not exceed 16 feet, when traveling on a roadway of four or more lanes; and

(C) have a front and a rear escort vehicle for all roads, when the width of the load exceeds 16 feet.

(3) Escort requirements for overlength loads. Unless an exception is granted by the MCD, based on a route and traffic study, overlength loads must have:

(A) a front escort vehicle when traveling on a two lane roadway if the vehicle exceeds 110 feet overall length, but does not exceed 125 feet overall length;

(B) a rear escort vehicle when traveling on a multi-lane highway if the vehicle exceeds 110 feet overall length, but does not exceed 125 feet overall length; and

(C) a front and rear escort vehicle at all times if the permitted vehicle exceeds 125 feet overall length.

(4) Escort requirements for overheight loads. Unless an exception is granted by the MCD, based on a route and traffic study, overheight loads must have:

(A) a front escort vehicle equipped with a height pole to accurately measure overhead obstructions for any permitted vehicle that exceeds 17 feet in height; and

(B) a front and rear escort vehicle for any permitted vehicle exceeding 18 feet in height.

(5) Escort requirements for permitted vehicles exceeding legal limits in more than one dimension. When a load exceeds more than one dimension that requires an escort under this subsection, front and rear escorts will be required unless an exception is granted by the MCD. For example, under this subsection one escort is required for a load exceeding 14 feet in width, and one escort is required for a load exceeding 110 feet in length. In the case of a permitted vehicle that exceeds both 14 feet in width and 110 feet in length, both front and rear escorts are required.

(6) Escort requirements for convoys. Convoys must have a front escort vehicle and a rear escort vehicle on all highways at all times.

(7) General equipment requirements. The following special equipment requirements apply to permitted vehicles and escort vehicles that are not motorcycles.

(A) An escort vehicle must be a single unit with a gross vehicle weight (GVW) of not less than 1,000 pounds nor more than 10,000 pounds.

(B) An escort vehicle must be equipped with two flashing amber lights or one rotating amber beacon of not less than eight inches in diameter, affixed to the roof of the escort vehicle, which must be visible to the front, sides, and rear of the escort vehicle while actively engaged in escort duties for the permitted vehicle.

(C) An escort vehicle must display a sign, on either the roof of the vehicle, or the front and rear of the vehicle, with the words "OVERSIZE LOAD" or "WIDE LOAD." The sign must be visible from the front and rear of

the vehicle while escorting the permitted load. The sign must meet the following specifications:

- (i) at least five feet, but not more than seven feet in length, and at least 12 inches, but not more than 18 inches in height;
- (ii) the sign must have a yellow background with black lettering;
- (iii) letters must be at least eight inches, but not more than 10 inches high with a brush stroke at least 1.41 inches wide; and
- (iv) the sign must be visible from the front or rear of the vehicle while escorting the permitted vehicle, and the signs must not be used at any other time.

(D) An escort vehicle must maintain two-way communications with the permitted vehicle and other escort vehicles involved with the movement of the permitted vehicle.

(E) Warning flags must be either red or orange fluorescent material, at least 12 inches square, securely mounted on a staff or securely fastened by at least one corner to the widest extremities of an overwidth permitted vehicle, and at the rear of an overlength permitted vehicle or a permitted vehicle with a rear overhang in excess of four feet.

(8) Equipment requirements for motorcycles.

(A) An official law enforcement motorcycle may be used as a primary escort vehicle for a permitted vehicle traveling within the limits of an incorporated city, if the motorcycle is operated by a highway patrol officer, sheriff, or duly authorized deputy, or municipal police officer.

(B) An escort vehicle must maintain two-way communications with the permitted vehicle and other escort vehicles involved with the movement of the permitted vehicle.

(l) Restrictions.

(1) Restrictions pertaining to road conditions. Movement of a permitted vehicle is prohibited when road conditions are hazardous based upon the judgement of the operator and law enforcement officials. Law enforcement officials shall make the final determination regarding whether or not conditions are hazardous. Conditions that should be considered hazardous include, but are not limited to:

- (A) visibility of less than 2/10 of one mile; or
- (B) weather conditions such as wind, rain, ice, sleet, or snow.

(2) Daylight and night movement restrictions.

(A) A permitted vehicle may be moved only during daylight hours unless:

- (i) the permitted vehicle is overweight only;
 - (ii) the permitted vehicle is traveling on an interstate highway and does not exceed 10 feet wide and 100 feet long, with front and rear overhang that complies with legal standards; or
 - (iii) the permitted vehicle meets the criteria of clause (ii) of this subparagraph and is overweight.
-

(B) An exception may be granted allowing night movement, based on a route and traffic study conducted by the MCD. Escorts may be required when an exception allowing night movement is granted.

(3) Weekend and holiday restrictions. The maximum size limits for a permit issued under Transportation Code, Chapter 622, Subchapter E and Chapter 623, Subchapters D and E, for holiday movement is 14 feet wide, 16 feet high, and 110 feet long, unless an exception is granted by the MCD based on a route and traffic study. The department may restrict weekend and holiday movement of specific loads based on a determination that the load could pose a hazard for the traveling public due to local road or traffic conditions.

(4) Curfew restrictions. The operator of a permitted vehicle must observe the curfew movement restrictions of any city in which the vehicle is operated.

(m) General provisions.

(1) Multiple commodities.

(A) Except as provided in subparagraph (B) of this paragraph, when a permitted commodity creates a single overdimension, two or more commodities may be hauled as one permit load, provided legal axle weight and gross weight are not exceeded, and provided an overdimension of width, length or height is not created or made greater by the additional commodities. For example, a permit issued for the movement of a 12 foot wide storage tank may also include a 10 foot wide storage tank loaded behind the 12 foot wide tank provided that legal axle weight and gross weight are not exceeded, and provided an overdimension of width, length or height is not created.

(B) When the transport of more than one commodity in a single load creates or makes greater an illegal dimension of length, width, or height the department may issue an oversize permit for such load subject to each of the following conditions.

(i) The permit applicant or the shipper of the commodities files with the department a written certification by the Texas Department of Economic Development, approved by the Office of the Governor, attesting that issuing the permit will have a significant positive impact on the economy of Texas and that the proposed load of multiple commodities therefore cannot be reasonably dismantled. As used in this clause the term significant positive impact means the creation of not less than 100 new full-time jobs, the preservation of not less than 100 existing full-time jobs, that would otherwise be eliminated if the permit is not issued, or creates or retains not less than one percent of the employment base in the affected economic sector identified in the certification.

(ii) Transport of the commodities does not exceed legal axle and gross load limits.

(iii) The permit is issued in the same manner and under the same provisions as would be applicable to the transport of a single oversize commodity under this section; provided, however, that the shipper and the permittee also must indemnify and hold harmless the department, its commissioners, officers, and employees from any and all liability for damages

or claims of damages including court costs and attorney fees, if any, which may arise from the transport of an oversized load under a permit issued pursuant to this subparagraph.

(iv) The shipper and the permittee must file with the department a certificate of insurance on a form prescribed by the department, or otherwise acceptable to the department, naming the department, its commissioners, officers, and employees as named or additional insurers on its comprehensive general liability insurance policy for coverage in the amount of \$5 million per occurrence, including court costs and attorney fees, if any, which may arise from the transport of an oversized load under a permit issued pursuant to this subparagraph. The insurance policy is to be procured from a company licensed to transact insurance business in the State of Texas.

(v) The shipper and the permittee must file with the department, in addition to all insurance provided in clause (iv) of this subparagraph, a certificate of insurance on a form prescribed by the department, or otherwise acceptable to the department, naming the department, its commissioners, officers, and employees as insurers under an auto liability insurance policy for the benefit of said insurers in an amount of \$5 million per accident. The insurance policy is to be procured from a company licensed to transact insurance business in the State of Texas. If the shipper or the permittee is self-insured with regard to automobile liability then that party must take all steps and perform all acts necessary under the law to indemnify the department, its commissioners, officers, and employees as if the party had contracted for insurance pursuant to, and in the amount set forth in, the preceding sentence and shall agree to so indemnify the department, its commissioners, officers, and employees in a manner acceptable to the department.

(vi) Issuance of the permit is approved by written order of the commission which written order may be, among other things, specific as to duration and routes.

(C) An applicant requesting a permit to haul a dozer and its detached blade may be issued a permit, as a non-dismantable load, if removal of the blade will decrease the overall width of the load, thereby reducing the hazard to the traveling public.

(2) Oversize hauling equipment. A vehicle that exceeds the legal size limits, as set forth by Transportation Code, Chapter 621, Subchapter C, may only haul a load that exceeds legal size limits unless otherwise noted in this subchapter, but such vehicle may haul an overweight load that does not exceed legal size limits, except for the special exception granted in §28.13(b)(4) of this subchapter (relating to Time Permits issued under Transportation Code, Chapter 623, Subchapter D).

(n) Surety bonds.

(1) General. The following conditions apply to surety bonds specified in Transportation Code, §623.075.

(A) The surety bond must:

- (i) be made payable to the department with the condition that the applicant will pay the department for any damage caused to the highway by the operation of the equipment covered by the surety bond;
- (ii) be effective the day it is issued and expires at the end of the state fiscal year, which is August 31st. For example, if you obtain a surety bond on August 30th, it will expire the next day at midnight.
- (iii) include the complete mailing address and zip code of the principal;
- (iv) be filed with the MCD and have an original signature of the principal;
- (v) have a single entity as principal with no other principal names listed; and
- (vi) A non-resident agent with a valid Texas insurance license may issue a bond on behalf of an authorized insurance company when in compliance with Insurance Code, Chapter 4056.

(B) A certificate of continuation will not be accepted.

(C) The owner of a vehicle bonded under Transportation Code, §622.013, §623.075, and §623.163, that damages the state highway system as a result of the permitted vehicle's movement will be notified by certified mail of the amount of damage and will be given 30 days to submit payment for such damage. Failure to make payment within 30 days will result in the department's placing the claim with the attorney general for collection.

(D) The venue of any suit for a claim against a surety bond for the movement of a vehicle permitted under the provisions of Transportation Code, Chapter 623, Subchapter D, will be any court of competent jurisdiction in Travis County.

(2) Permit surety bonds.

(A) A surety bond required under the provisions of Transportation Code, Chapter 623, Subchapter D, must be submitted on the department's standard surety bond form in the amount of \$10,000.

(B) A facsimile or electronic copy of the surety bond is acceptable in lieu of the original surety bond, for a period not to exceed 10 days from the date of its receipt in the MCD. If the original surety bond has not arrived in the MCD by the end of the 10 days, the applicant will not be issued a permit until the original surety bond has been received in the MCD.

(C) The surety bond requirement does apply to the delivery of farm equipment to a farm equipment dealer.

(D) A surety bond is required when a dealer or transporter of farm equipment or a manufacturer of farm equipment obtains a permit.

(E) The surety bond requirement does not apply to driving or transporting farm equipment which is being used for agricultural purposes if it is driven or transported by or under the authority of the owner of the equipment.

(F) The surety bond requirement does not apply to a vehicle or equipment operated by a motor carrier registered with the department under Transportation Code, Chapters 643 or 645 as amended.

RULE §28.12 Single-Trip Permits Issued Under Transportation Code, Chapter 623, Subchapter D

(a) General. The information in this section applies to single trip permits issued under Transportation Code, Chapter 623, Subchapter D. The department will issue permits under this section in accordance with the requirements of §28.11 of this subchapter (relating to General Oversize/Overweight Permit Requirements and Procedures).

(b) Overweight loads.

(1) The maximum weight limits for an overweight permit are specified in §28.11(d) of this subchapter.

(2) The applicant shall pay, in addition to the single-trip permit fee of \$60, the applicable highway maintenance fee described in §28.11(c)(3)(B) of this subchapter.

(3) A permit issued for an overdimension load exceeding 200,000 pounds gross weight will have a total permit fee that includes the single-trip permit fee, the highway maintenance fee, and the applicable vehicle supervision fee (VSF) described in §28.11(c)(3)(C) of this subchapter.

(A) When a permit is issued under this subsection, and the permittee has additional identical loads that are to be moved over the same route within 30 days of the movement date of the original permit, a reduced vehicle supervision fee of \$35 will be charged in lieu of the full vehicle supervision fee.

(B) An applicant for a permit issued under paragraph (8) of this subsection must pay the vehicle supervision fee at the time of permit application in order to offset department costs for analyses performed in advance of issuing the permit. A request for cancellation must be in writing and received by the department prior to collection of the structural information associated with the permit application. If the application is canceled, the department will return the vehicle supervision fee.

(4) An applicant applying for a permit to move a load that is required for the fulfillment of a fixed price public works contract that was entered into prior to the effective date of this section, and administered by federal, state, or local governmental entities, will not be required to pay the vehicle supervision fee, provided the applicant presents proof of the contract to the MCD prior to permit issuance.

(5) When the department has determined that a permit can be issued for an overdimension load exceeding 200,000 pounds gross weight, all remaining fees are due at the time the permit is issued.

(6) The department will not charge an analysis fee for single and multiple box culverts.

(7) An applicant requesting a permit to move an overdimension load that is between 200,001 and 254,300 pounds total with less than 95 feet overall axle spacing, or is over the maximum permitted weight on any axle or axle group, or is over 254,300 pounds gross weight, or the weight limits described in §28.11(d)

of this subchapter, must submit the following items to the MCD to determine if the permit can be issued:

(A) a detailed loading diagram which indicates the number of axles, the number of tires on each axle, the tire size on each axle, the distance between each axle, the tare and gross weight on each axle, the transverse spacing of each set of dual wheels, the distance between each set of dual wheels, the load's center of gravity, the distance from the center of gravity to the center of the front bolster, the distance from the center of gravity to the center of the rear bolster, the distance from the center of the front bolster to the center of the fifth wheel of the truck, the distance from the center of the rear bolster to the center of the closest axle, and any other measurements as may be needed to verify that the weight of the overdimension load is adequately distributed among the various axle groups in the amounts indicated by the loading diagram;

(B) a map indicating the exact beginning and ending points relative to a state highway;

(C) a copy of the signed contract indicating that the applicant has been retained to transport the shipment;

(D) the vehicle supervision fee as specified in paragraph (3) of this subsection; and

(E) the name, phone number, and fax number of the applicant's licensed professional engineer who has been approved by the department.

(8) The MCD will select a tentative route based on the physical size of the overdimension load excluding the weight. The tentative route must be investigated by the applicant, and the MCD must be advised, in writing, that the route is capable of accommodating the overdimension load.

(9) Before the permit is issued, the applicant's licensed professional engineer shall submit to the Bridge Division a written certification that includes a detailed structural analysis of the bridges on the proposed route demonstrating that the bridges and culverts on the travel route are capable of sustaining the load. The certification must be approved by the department before the permit will be issued.

(10) A permit may be issued for the movement of oversize and overweight self-propelled off road equipment under the following guidelines.

(A) The weight per inch of tire width must not exceed 650 pounds.

(B) The rim diameter of each wheel must be a minimum of 25 inches.

(C) The maximum weight per axle must not exceed 45,000 pounds.

(D) The minimum spacing between axles, measured from center of axle to center of axle, must not be less than 12 feet.

(E) The equipment must be moved empty.

(F) The equipment must be licensed with a machinery license plate or a one trip registration.

(G) The route will not include any controlled access highway, unless an exception is granted based on a route and traffic study conducted by the MCD.

(c) Drill pipe and drill collars hauled in a pipe box.

(1) A vehicle or combination of vehicles may be issued a permit under Transportation Code, §623.071, to haul drill pipe and drill collars in a pipe box.

(2) The maximum width must not exceed nine feet.

(3) The axle weight limits must not exceed the maximum weight limits as specified in §28.11(d)(3) of this subchapter.

(4) The height and length must not exceed the legal limits specified in Transportation Code, Chapter 621, Subchapter C.

(5) The permit will be issued for a single-trip only, and the fee will be \$60. For loads over 80,000 pounds, a highway maintenance fee will be charged as specified in §28.11(c)(3)(B) of this subchapter.

(6) The permit is valid only for travel on any farm-to-market and ranch-to-market road, and such road will be specified on the permit; however, the permitted vehicle will not be allowed to cross any load restricted bridge when exceeding the posted capacity of the bridge.

(7) Movement will be restricted to daylight hours only.

(d) Houses and storage tanks.

(1) Unless an exception is granted by the MCD, approval for the issuance of a permit for a house or storage tank exceeding 20 feet in width will reside with each district engineer, or the district engineer's designee, along the proposed route.

(2) The issuance of a permit for a house or storage tank exceeding 20 feet in width will be based on:

(A) the amount of inconvenience and hazard to the traveling public, based on traffic volume;

(B) highway geometrics and time of movement; and

(C) the overall width, measured to the nearest inch, of the house, including the eaves or porches.

(3) A storage tank must be empty.

(4) The proposed route must include the beginning and ending points on a state highway.

(5) A permit will not be issued for a newly constructed house or storage tank that exceeds 34 feet overall width unless an exception is granted by the MCD based on a route and traffic study.

(6) A permit will not be issued for the relocation of an existing house or storage tank that exceeds 40 feet overall width, unless an exception is granted by the MCD based on a route and traffic study.

(7) A permit may be issued for the movement of an overweight house provided:

(A) the applicant completes and submits to the MCD a copy of a diagram for moving overweight houses, as shown in Appendix A of this section;

(B) each support beam, parallel to the centerline of the highway, is equipped with an identical number of two axle groups which may be placed directly in line and across from the other corresponding two axle group or

may be placed in a staggered offset arrangement to provide for proper weight distribution;

(C) that, when a support beam is equipped with two or more two axle groups, each two axle group is connected to a common mechanical or hydraulic system to ensure that each two axle group shares equally in the weight distribution at all times during the movement; and when the spacing between the two axle groups, measured from the center of the last axle of the front group to the center of the first axle of the following group, is eight feet or more, the front two axle group is equipped for self-steering in a manner that will guide or direct the axle group in turning movements without tire scrubbing or pavement scuffing; and

(D) the department conducts a detailed analysis of each structure on the proposed route and determines the load can be moved without damaging the roads and bridges.

(8) The MCD may waive the requirement that a loading diagram be submitted for the movement of an overweight house if the total weight of all axle groups located in the same transverse plane across the house does not exceed the maximum weight limits specified in §28.11(d)(2) of this subchapter.

(e) Diagram for moving overweight houses. The following Appendix A indicates the type of diagram that is to be completed by the permit applicant for moving an overweight house. All measurements must be stated to the nearest inch.

Figure: 43 TAC §28.12(e)

Appendix A – Example Diagrams for Moving Overweight Houses

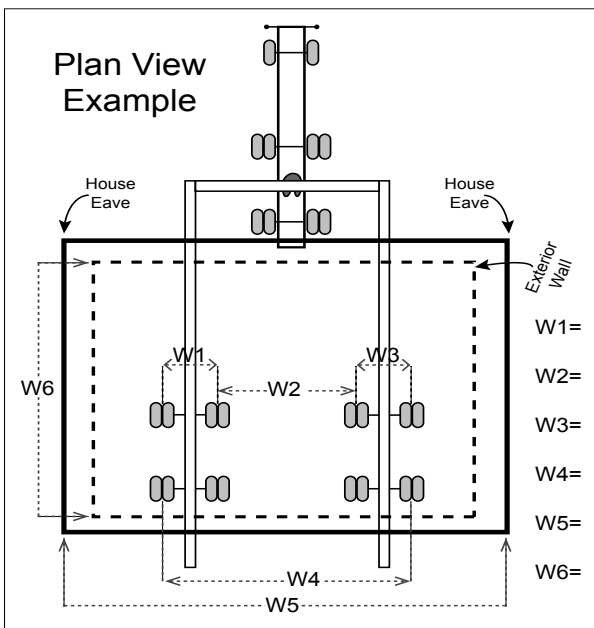

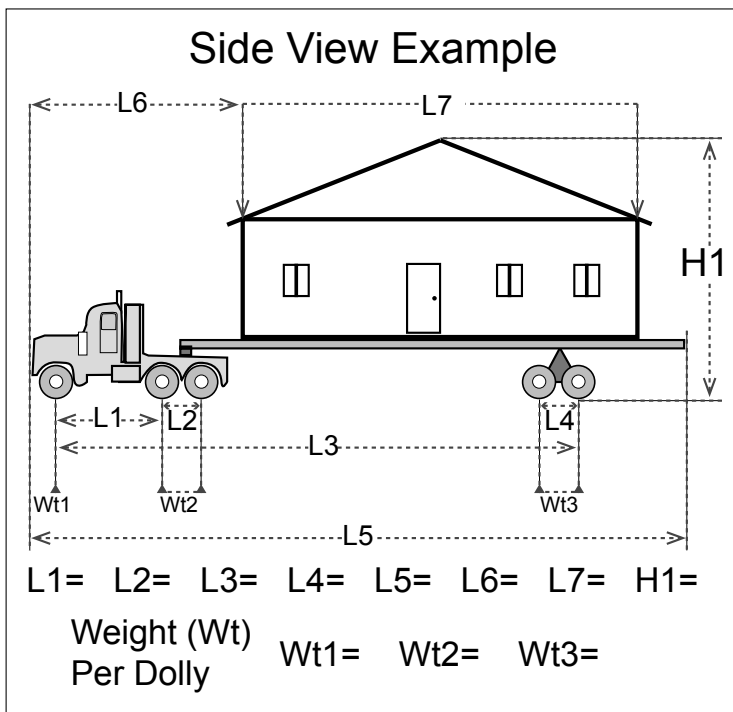

RULE §28.13 Time Permits

(a) General information. Applications for time permits issued under Transportation Code, Chapter 623, and this section shall be made in accordance with §28.11(c) of this subchapter (relating to General Oversize/Overweight Permit Requirements and Procedures). Permits issued under this section are governed by the requirements of §28.11(e)(1) and (4) of this subchapter.

(b) 30, 60, and 90 day permits. The following conditions apply to time permits issued for overwidth or overlength loads, or overlength vehicles, under this section.

(1) Fees. The fee for a 30-day permit is \$120; the fee for a 60-day permit is \$180; and the fee for a 90-day permit is \$240. All fees are payable in accordance with §28.11(f) of this subchapter. All fees are non-refundable.

(2) Validity of Permit. Time permits are valid for a period of 30, 60, or 90 calendar days, based on the request of the applicant, and will begin with the “movement to begin” date stated on the permit.

(3) Weight/height limits. The permitted vehicle may not exceed the weight or height limits set forth by Transportation Code, Chapter 621, Subchapters B and C.

(4) Registration requirements for permitted vehicles. The permitted vehicle must be registered in accordance with Transportation Code, Chapter

502, for maximum weight for the vehicle or vehicle combination as set forth by Transportation Code, §502.151. Time permits will not be issued to a vehicle or vehicle combination that is registered with temporary vehicle registration.

(5) Vehicle indicated on permit. The permit will indicate only the truck or truck-tractor transporting the load; however, any properly registered trailer or semi-trailer is covered by the permit.

(6) Permit routes. The permit will allow travel on a statewide basis.

(7) Restrictions.

(A) The permitted vehicle must not cross a load restricted bridge or load restricted road when exceeding the posted capacity of the road or bridge.

(B) The permitted vehicle may travel through highway construction or maintenance areas if the dimensions do not exceed the construction restrictions as published by the department.

(C) The permitted vehicle is subject to the restrictions specified in §28.11(l) of this subchapter, and the permittee is responsible for obtaining from the department information concerning current restrictions.

(8) Escort requirements. Permitted vehicles are subject to the escort requirements specified in §28.11(k) of this subchapter.

(9) Transfer of time permits. Time permits issued under this subsection are non-transferable between permittees or vehicles.

(10) Amendments. With the exception of time permits issued under subsection (e)(4) of this section, time permits issued under this subsection will not be amended except in the case of permit officer error.

(c) Overwidth loads. An overwidth time permit may be issued for the movement of any non-divisible load or overwidth trailer, subject to subsection (a) of this section and the following conditions.

(1) Width requirements. A time permit will not be issued for a vehicle with a width exceeding 13 feet.

(2) Weight, height, and length requirements. The permitted vehicle shall not exceed legal weight, height, or length according to Transportation Code, Chapter 621, Subchapters B and C. When multiple items are hauled at the same time, the items may not be loaded in a manner that creates:

(A) a width greater than the width of the widest item being hauled;

(B) a height greater than 14 feet;

(C) an overlength load; or

(D) a gross weight exceeding the legal gross or axle weight of the vehicle hauling the load.

(3) Movement of overwidth trailers. When the permitted vehicle is an overwidth trailer, it will be permitted to:

(A) move empty to and from the job site; and

(B) return from the job site to the permittee's place of business with a legal nondivisible load.

(4) Use in conjunction with other permits. An overwidth time permit may be used in conjunction with an overlength time permit.

(d) Overlength loads. An overlength time permit may be issued for the transportation of overlength loads or the movement of an overlength self-propelled vehicle, subject to subsection (a) of this section and the following conditions.

(1) Length requirements. The maximum overall length for the permitted vehicle may not exceed 110 feet.

(2) Weight, height and width requirements. The permitted vehicle may not exceed legal weight, height, or width according to Transportation Code, Chapter 621, Subchapters B and C.

(A) The maximum length for a single permitted vehicle may not exceed 75 feet.

(B) A permit will not be issued when the load has more than 25 feet front overhang, or more than 30 feet rear overhang, unless an exception is granted by the department's Motor Carrier Division, based on a route and traffic study.

(3) Use in conjunction with other permits. An overlength time permit may be used in conjunction with an overwidth time permit.

(4) Emergency movement. A permitted vehicle transporting utility poles will be allowed emergency night movement for restoring electrical utility service, provided the permitted vehicle is accompanied by a rear escort vehicle.

(e) Annual permits.

(1) General information. All permits issued under this subsection are subject to the following conditions.

(A) Fees for permits issued under this subsection are payable as described in §28.11(f) of this subchapter.

(B) Permits issued under this subsection are not transferable.

(C) Vehicles permitted under this subsection shall be operated according to the restrictions described in §28.11(l) of this subchapter. The permittee is responsible for obtaining information concerning current restrictions from the department.

(D) Vehicles permitted under this subsection may not travel over a load restricted bridge or load restricted road when exceeding the posted capacity of the road or bridge.

(E) Vehicles permitted under this subsection may travel through any highway construction or maintenance area provided the dimensions do not exceed the construction restrictions as published by the department.

(F) With the exception of permits issued under paragraph (5) of this subsection, vehicles permitted under this subsection shall be operated according to the escort requirements described in §28.11(k) of this subchapter.

(2) Implements of husbandry. An annual permit may be issued for an implement of husbandry being moved by a dealer in those implements, and for harvesting equipment being moved as part of an agricultural operation. Permits issued under this paragraph are subject to the conditions described in paragraph (1) of this subsection.

(A) The fee for a permit issued under this paragraph is \$270, plus the highway maintenance fee specified in Transportation Code, §623.077 and §28.11(c)(3)(B) of this subchapter.

(B) The time period will be for one year and will start with the “movement to begin” date stated on the permit.

(C) The maximum width may not exceed 16 feet; maximum height may not exceed 16 feet; maximum length may not exceed 110 feet; and maximum weight may not exceed the limits stated in §28.11(d) of this subchapter.

(D) The permitted vehicle must travel in the outside traffic lane on multi-lane highways, when the width of the load exceeds 12 feet.

(E) The permitted vehicle must be registered in accordance with Transportation Code, Chapter 502, for maximum weight for the vehicle or vehicle combination, as set forth by Transportation Code, Chapter 621.

(3) Water well drilling machinery. The department may issue annual permits under Transportation Code, §623.071, for water well drilling machinery and equipment that cannot be reasonably dismantled. Permits issued under this paragraph are subject to the conditions described in paragraph (1) of this subsection.

(A) The fee for a permit issued under this paragraph is \$270, plus the highway maintenance fee specified in Transportation Code, §623.077, and §28.11(c)(3)(B) of this subchapter, for an overweight load.

(B) A water well drilling machinery permit is valid for one year from the “movement to begin” date stated on the permit.

(C) The maximum dimensions may not exceed 16 feet wide, 14 feet 6 inches high, 110 feet long, and maximum weight may not exceed the limits stated in §28.11(d) of this subchapter.

(D) The permitted vehicle must be registered in accordance with Transportation Code, Chapter 502, for the maximum weight of the vehicle, as set forth by Transportation Code, Chapter 621.

(E) A permit issued under this section authorizes a permitted vehicle to operate only on the state highway system.

(4) Envelope vehicle permits.

(A) The department may issue an annual permit under Transportation Code, §623.071(c), to a specific vehicle, for the movement of superheavy or oversize equipment that cannot reasonably be dismantled. Unless otherwise noted, permits issued under this paragraph are subject to the conditions described in paragraph (1) of this subsection.

(i) Superheavy or oversize equipment operating under an annual envelope vehicle permit may not exceed:

- (I) 12 feet in width;
- (II) 14 feet in height;
- (III) 110 feet in length; or
- (IV) 120,000 pounds gross weight.

(ii) Superheavy or oversize equipment operating under an annual envelope vehicle permit may not transport a load that has more than 25 feet front overhang, or more than 30 feet rear overhang.

(iii) The fee for an annual envelope vehicle permit is \$4,000, and is non-refundable.

(iv) The time period will be for one year and will start with the “movement to begin” date stated on the permit.

(v) This permit authorizes operation of the permitted vehicle only on the state highway system.

(vi) The permitted vehicle must comply with §28.11(d)(2) and (3) of this subchapter.

(vii) The permitted vehicle or vehicle combination must be registered in accordance with Transportation Code, Chapter 502, for maximum weight as set forth by Transportation Code, Chapter 621.

(viii) A permit issued under this paragraph is non-transferable between permittees.

(ix) A permit issued under this paragraph may be transferred from one vehicle to another vehicle in the permittee’s fleet provided:

(I) the permitted vehicle is destroyed or otherwise becomes permanently inoperable, to an extent that it will no longer be utilized, and the permittee presents proof that the negotiable certificate of title or other qualifying documentation has been surrendered to the department; or

(II) the certificate of title to the permitted vehicle is transferred to someone other than the permittee, and the permittee presents proof that the negotiable certificate of title or other qualifying documentation has been transferred from the permittee.

(x) A single trip permit, as described in §28.12 of this subchapter (relating to Single Trip Permits Issued Under Transportation Code, Chapter 623, Subchapter D), may be used in conjunction with an annual permit issued under this paragraph for the movement of vehicles or loads exceeding the height or width limits established in subparagraph (A) of this paragraph. The department will indicate the annual permit number on any single trip permit to be used in conjunction with a permit issued under this paragraph, and permittees will be assessed a fee of \$60 for the single trip permit.

(B) The department may issue an annual permit under Transportation Code, §623.071(d), to a specific motor carrier, for the movement of superheavy or oversize equipment that cannot reasonably be dismantled. Unless otherwise noted, permits issued under this paragraph are subject to the conditions described in paragraph (1) of this subsection and subparagraph (A)(i) - (viii) of this paragraph. A permit issued under this paragraph may be transferred from one vehicle to another vehicle in the permittee’s fleet provided:

(i) that no more than one vehicle is operated at a time; and

(ii) the original certified permit is carried in the vehicle that is being operated under the terms of the permit.

(C) An annual envelope permit issued under subparagraph (B) of this paragraph will be sent to the permittee via registered mail, or at the permittee's request and expense overnight delivery service. This permit may not be duplicated. This permit will be replaced only if:

(i) the permittee did not receive the original permit within seven business days after its date of issuance;

(ii) a request for replacement is submitted to the department within 10 business days after the original permit's date of issuance; and

(iii) the request for replacement is accompanied by a notarized statement signed by a principle or officer of the permittee acknowledging that the permittee understands the permit may not be duplicated and that if the original permit is located, the permittee must return either the original or replacement permit to the department.

(D) A request for replacement of a permit issued under subparagraph (B) of this paragraph will be denied if the department can verify that the permittee received the original.

(E) Lost, misplaced, damaged, destroyed, or otherwise unusable permits will not be replaced. A new permit will be required.

(5) Annual manufactured housing permit. The department may issue an annual permit for the transportation of new manufactured homes from a manufacturing facility to a temporary storage location, not to exceed 20 miles from the point of manufacture, in accordance with Transportation Code, §623.094. Permits issued under this paragraph are subject to the requirements of paragraph (1), subparagraphs (A), (B), (C), (D), (E), and (G), of this subsection.

(A) A permit shall contain the name of the company or person authorized to be issued permits by Transportation Code, Chapter 623, Subchapter E.

(B) The fee for a permit issued under this paragraph is \$1,500. Fees are non-refundable, and shall be paid in accordance with §28.11(f) of this subchapter.

(C) The time period will be for one year from the "movement to begin" date stated on the permit.

(D) A copy of the permit must be carried in the vehicle transporting a manufactured home.

(E) The permitted vehicle must travel in the outside traffic lane on multi-lane highways when the width of the load exceeds 12 feet.

(F) The permitted vehicle must be registered in accordance with Transportation Code, Chapter 502.

(G) Authorized movement for a vehicle permitted under this section shall be valid during daylight hours only as defined by Transportation Code, §541.401.

(H) The permitted vehicle must be operated in accordance with the escort requirements described in §28.14(f) of this subchapter (relating to Manufactured Housing, and Industrialized Housing and Building Permits).

(I) Permits issued under this section are non-transferable between permittees.

(6) Power line poles. An annual permit will be issued under Transportation Code, Chapter 622, Subchapter E, for the movement of poles required for the maintenance of electric power transmission and distribution lines. Permits issued under this paragraph are subject to the conditions described in paragraph (1) of this subsection.

(A) The fee for the permit is \$120.

(B) The time period will be for one year and will start with the “movement to begin” date stated on the permit.

(C) The maximum length of the permitted vehicle may not exceed 75 feet.

(D) The width, height and gross weight of the permitted vehicle may not exceed the limits set forth by Transportation Code, Chapter 621.

(E) Vehicles permitted under this paragraph may not travel over a load restricted bridge or load zoned road when exceeding posted limits.

(F) The permitted vehicle must be registered in accordance with Transportation Code, Chapter 502, for maximum weight as set forth by Transportation Code, Chapter 621.

(G) Movement will be between the hours of sunrise and sunset; however, the limitation on hours of operation does not apply to a vehicle being operated to prevent interruption or impairment of electric service, or to restore electric service that has been interrupted. When operated at night, a vehicle permitted under this subsection must be accompanied by a rear escort.

(H) The permitted vehicle may not travel during hazardous road conditions as stated in §28.11(I)(1)(A) and (B) except to prevent interruption or impairment of electric service, or to restore electric service that has been interrupted.

(I) The speed of the permitted vehicle may not exceed 50 miles per hour.

(J) The permitted vehicle must display on the extreme end of the load:

(i) two red lamps visible at a distance of at least 500 feet from the rear;

(ii) two red reflectors that indicate the maximum width and are visible, when light is insufficient or atmospheric conditions are unfavorable, at all distances from 100 to 600 feet from the rear when directly in front of lawful lower beams of headlamps; and

(iii) two red lamps, one on each side, that indicate the maximum overhang, and are visible at a distance of at least 500 feet from the side of the vehicle.

(7) Cylindrically shaped bales of hay. An annual permit may be issued under Transportation Code, §621.017, for the movement of vehicles transporting cylindrically shaped bales of hay. Permits issued under this paragraph are subject to the conditions described in paragraph (1) of this subsection.

- (A) The permit fee is \$10.
- (B) The time period will be for one year, and will start with the “movement to begin” date stated on the permit.
- (C) The maximum width of the permitted vehicle may not exceed 12 feet.
- (D) The length, height, and gross weight of the permitted vehicle may not exceed the limits set forth by Transportation Code, Chapter 621.
- (E) Movement is restricted to daylight hours only.
- (F) The permitted vehicle must be registered in accordance with Transportation Code, Chapter 502, for maximum weight, as set forth by Transportation Code, Chapter 621.

RULE §28.14 Manufactured Housing, and Industrialized Housing and Building Permits

(a) General information.

- (1) A manufactured home that exceeds size limits for motor vehicles as defined by Transportation Code, Chapter 621, Subchapters B and C, must obtain a permit from the department.
- (2) Pursuant to Transportation Code, Chapter 623, Subchapter E, a permit may be issued to persons registered as manufacturers, installers, or retailers with the Texas Department of Housing and Community Affairs or motor carriers registered with the department under Transportation Code, Chapter 643.
- (3) The department may issue a permit to the owner of a manufactured home provided that:
 - (A) the same owner is named on the title of the manufactured home and towing vehicle;
 - (B) or the owner presents a lease showing that the owner of the manufactured home is the lessee of the towing vehicle.

(b) Application for permit.

- (1) The applicant must complete the application and shall include the manufactured home’s HUD label number, Texas seal number, or the complete identification number or serial number of the manufactured home, and the overall width, height, and length of the home and the towing vehicle in combination. If the manufactured home is being moved to or from a site in this state where it has been, or will be, occupied as a dwelling, the permit must also show the name of the owner of the home, the location from which the home is being moved, and the location to which the home is being delivered.
- (2) A permit application for industrialized housing or industrialized building that does not meet the definition in Occupations Code, §1202.002 and §1202.003 shall be submitted in accordance with §28.11(c) of this subchapter (relating to General Oversize/Overweight Permit Requirements and Procedures).

(c) Permit issuance.

- (1) Permit issuance is subject to the requirements of §28.11(e)(4) of this subchapter (relating to General Oversize/Overweight Permit Requirements and Procedures).

(2) Amendments can only be made to change intermediate points between the origination and destination points listed on the permit.

(d) Payment of permit fee. The cost of the permit is \$40, payable in accordance with §28.11(f) of this subchapter (relating to General Oversize/Overweight Permit Requirements and Procedures).

(e) Permit provisions and conditions.

(1) The overall combined length of the manufactured home and the towing vehicle includes the length of the hitch or towing device.

(2) The height is measured from the roadbed to the highest elevation of the manufactured home.

(3) The width of a manufactured home includes any roof or eaves extension or overhang on either side.

(4) A permit will be issued for a single continuous movement not to exceed five days.

(5) Movement must be made during daylight hours only and may be made on any day except New Year's Day, Memorial Day, Independence Day, Labor Day, Thanksgiving Day, and Christmas Day.

(6) The department may limit the hours for travel on certain routes because of heavy traffic conditions.

(7) The department will publish any limitations on movements during the national holidays listed in this subsection, or any limitations during certain hours of heavy traffic conditions, and will make such publications available to the public prior to the limitations becoming effective.

(8) The permit will contain the route for the transportation of the manufactured home from the point of origin to the point of destination.

(9) The route for the transportation must be the most practical route as described in §28.11(e) of this subchapter (relating to General Oversize/Overweight Permit Requirements and Procedures), except where construction is in progress and the permitted vehicle's dimensions exceed the construction restrictions as published by the department, or where bridge or overpass width or height would create a safety hazard.

(10) The department will publish annually a map or list of all bridges or overpasses which, due to height or width, require an escort vehicle to stop oncoming traffic while the manufactured home crosses the bridge or overpass.

(11) A permittee may not transport a manufactured home with a void permit; a new permit must be obtained.

(f) Escort requirements.

(1) A manufactured home exceeding 12 feet in width must have a rotating amber beacon of not less than eight inches in diameter mounted somewhere on the roof at the rear of the manufactured home, or may have two five-inch flashing amber lights mounted approximately six feet from ground level at the rear corners of the manufactured home. The towing vehicle must have one rotating amber beacon of not less than eight inches in diameter mounted on top of the cab. These beacons or flashing lights must be operational

and luminiferous during any permitted move over the highways, roads, and streets of this state.

(2) A manufactured home with a width exceeding 16 feet but not exceeding 18 feet must have a front escort vehicle on two-lane roadways and a rear escort vehicle on roadways of four or more lanes.

(3) A manufactured home exceeding 18 feet in width must have a front and a rear escort on all roadways at all times.

(4) The escort vehicle must:

(A) have one red 16 inch square flag mounted on each of the four corners of the vehicle;

(B) have a sign mounted on the front and rear of the vehicle displaying the words "WIDE LOAD" in black letters at least eight inches high with a brush stroke at least 1.41 inches wide against a yellow background;

(C) have an amber light or lights, visible from both front and rear, mounted on top of the vehicle in one of the following configurations:

(i) two simultaneously flashing lights or

(ii) one rotating beacon of not less than eight inches in diameter; and

(D) maintain two-way communications with the permitted vehicle and other escort vehicles involved with the movement of the permitted vehicle.

(5) Two transportable sections of a multi-section manufactured home, or two single section manufactured homes, when towed together in convoy, may be considered one home for purposes of the escort vehicle requirements, provided the distance between the two units does not exceed 1,000 feet.

(6) An escort vehicle must comply with the requirements in §28.11(k)(1) and §28.11(k)(7)(A) of this subchapter (relating to General Oversize/Overweight Permit Requirements and Procedures).

RULE §28.15 Portable Building Unit Permits

(a) General information.

(1) A vehicle or vehicle combination transporting one or more portable building units and portable building compatible cargo that exceed legal length or width limits set forth by Transportation Code, Chapter 621, Subchapters B and C, may obtain a permit under Transportation Code, Chapter 623, Subchapter F.

(2) In addition to the fee required by subsection (d)(1), the department shall collect an amount equal to any fee that would apply to the movement of cargo exceeding any applicable width limits, if such cargo were moved in a manner not governed by this section.

(b) Application for permit. Applications shall be made in accordance with §28.11(c) of this title (relating to General Oversize/Overweight Permit Requirements and Procedures).

(c) Permit issuance. Permit issuance is subject to the requirements of §28.11(b)(1)(A) and (B) of this title (relating to General Oversize/Overweight

Permit Requirements and Procedures), with the exception of §28.11(k) of this title, concerning escort requirements.

(d) Payment of permit fee. The cost of the permit is \$15, with all fees payable in accordance with §28.11(f) of this title (relating to General Oversize/Overweight Permit Requirements and Procedures). All fees are non-refundable.

(e) Permit provisions and conditions.

(1) A portable building unit may only be issued a single-trip permit.

(2) Portable building units may be loaded end-to-end to create an overlength permit load, provided the overall length does not exceed 80 feet.

(3) Portable building units must not be loaded side-by-side to create an overwidth load, or loaded one on top of another to create an overheight load.

(4) Portable building units must be loaded in a manner that will create the narrowest width for permit purposes and provide for greater safety to the traveling public.

(5) The permit will be issued for a single continuous movement from the origin to the destination for an amount of time necessary to make the move, not to exceed 10 consecutive days.

(6) Movement of the permitted vehicle must be made during daylight hours only.

(7) A permittee may not transport portable building units or portable building compatible cargo with a void permit; a new permit must be obtained.

(f) Escort requirements.

(1) A portable building unit or portable building compatible cargo with a width exceeding 16 feet but not exceeding 18 feet must have a front escort vehicle on two-lane roadways and a rear escort vehicle on roadways of four or more lanes.

(2) A portable building unit or portable building compatible cargo exceeding 18 feet in width must have a front and a rear escort on all roadways at all times.

(3) The escort vehicle must:

(A) have one red 16 inch square flag mounted on each of the four corners of the vehicle;

(B) have a sign mounted on the front and rear of the vehicle displaying the words "WIDE LOAD" in black letters at least eight inches high with a brush stroke at least 1.41 inches wide against a yellow background;

(C) have an amber light or lights, visible from both front and rear, mounted on top of the vehicle and which must be two simultaneously flashing lights or one rotating beacon of not less than eight inches in diameter; and

(D) maintain two-way communications with the permitted vehicle and other escort vehicles involved with the movement of the permitted vehicle.

(4) An escort vehicle must comply with the requirements in §28.11(k)(1) and §28.11(k)(7)(A) of this title (relating to General Oversize/Overweight Permit Requirements and Procedures).

RULE §28.16 Permits for Military and Governmental Agencies

(a) The movement of an overdimension load on vehicles registered to the military or governmental agencies must obtain a permit from the MCD. Military or government applicants may apply for any applicable permit type issued by the department and shall follow all permit restrictions and requirements for the permit issued.

(b) The overdimension load must be moved on military or governmental vehicles that are licensed with either federal or state exempt license plates.

(c) The size and weight measurements of the overdimension load must not exceed the permit size and weight limits stated in §28.11(d) of this subchapter (relating to Maximum permit weight limits), and §28.12(b) of this subchapter (relating to Overweight loads), unless specific permission is granted by the MCD upon request of an authorized representative of the military or a governmental agency.

(d) A surety bond is not required for an overdimension governmental or military load hauled on governmental and military vehicles.

(e) The movement of an overdimension military or governmental load transported on vehicles not licensed with federal or state exempt license plates must obtain a permit, and must comply with §28.11 of this title (relating to Permit Issuance Requirements and Procedures), and §28.12 of this title (relating to Single-Trip Permits Issued under Transportation Code, Chapter 623, Subchapter D).

(f) A military or government entity is not required to pay the fee for a permit issued under this chapter if the load is transported only on vehicles that display federal or state exempt license plates.

RULE §28.17 Multi-state Permitting Agreements

(a) Agreements with other jurisdictions. In accordance with Texas Transportation Code §621.003, the director may enter into an agreement with the proper authority of another state that authorizes that authority to issue a permit on behalf of the department and authorizes the department to issue a permit on behalf of the proper authority of the other state. The agreement must be reviewed by the department's Office of General Counsel, before signing by the director.

(b) Permit fees.

(1) Permit fees collected by the department for another state under an agreement with another state shall be remitted to the state treasurer for deposit to the credit of an account in the general revenue fund to be known as the permit distributive account.

(2) Fees for a permit issued by the department under authority of an agreement on behalf of another state will be assessed as outlined by the agreement.

(3) Another state issuing a permit on behalf of this state shall collect fees for this state based on Texas laws and administrative rules.

(c) Validity of permit issued by proper authority in another state.

(1) A permit issued by the proper authority in another state under an agreement entered into by the director and that authority has the same validity in this state as a permit issued by the department.

(2) The holder of a permit issued by the proper authority in another state is subject to all applicable laws of this state and all applicable rules of the department.

SUBCHAPTER C – PERMITS FOR OVER AXLE AND OVER GROSS WEIGHT TOLERANCES

Rules

RULE §28.30 Permits for Over Axle and Over Gross Weight Tolerances

(a) Purpose. In accordance with Transportation Code, §623.011, the department is authorized under certain conditions to issue an annual permit for the operation of a vehicle within certain tolerances above legal axle and gross weight limits, as provided in Transportation Code, Chapter 621. The sections under this subchapter set forth the requirements and procedures to be used in issuing an annual permit.

(b) Scope. A permit may be issued to an applicant under this subchapter to operate a vehicle that exceeds the legal axle weight by a tolerance of 10% and the legal gross weight by a tolerance of 5.0% on any county road and on any road in the state highway system provided the vehicle:

(1) is not operated on the national system of interstate and defense highways at a weight greater than authorized by federal law; and

(2) is not operated on a bridge for which the maximum weight and load limit has been established and posted under Transportation Code, §621.102 or §621.301, if the gross weight of the vehicle and load or the axles and wheel loads are greater than the established and posted limits, unless the bridge provides the only public vehicular access to or from the permittee's origin or destination.

(c) Eligibility. To be eligible for a permit under this section, a vehicle must be registered under Transportation Code, Chapter 502, for the maximum gross weight applicable to the vehicle under Transportation Code, §621.101, not to exceed 80,000 pounds in total gross weight.

(d) Security.

(1) Before a permit may be issued under this section, an applicant, other than an applicant who intends to operate a vehicle that is loaded with timber or pulp wood, wood chips, cotton, or agricultural products in their natural state, must have on file with the department one of the following forms of security in the amount of \$15,000, conditioned that payment will be made to the department for any damages to the state highway system and to any county for damages to a road or bridge of such county caused by the operation of any vehicle for which a permit is issued under this section and which has an axle weight or gross weight that exceeds the weights authorized in Transportation Code, Chapter 621:

- (A) an irrevocable letter of credit issued by a financial institution which deposits are guaranteed by the Federal Deposit Insurance Corporation; or
- (B) a blanket surety bond.

(2) The department may reject a bond which it determines will not provide the intended security.

(3) If payment is made by the issuer in respect of the bond or letter of credit and the applicant does not file with the department a replacement bond or letter of credit in the full amount of \$15,000, or a notification from the issuer of the existing bond or letter of credit that the existing bond or letter of credit has been restored to the full \$15,000, within 30 days after the date of such payment, all permits held by the applicant under this section shall automatically expire on the 31st day after such date.

(e) Application for permit.

(1) A person who desires to permit a vehicle as provided in this section, must submit an application to the MCD.

(2) The application shall be in a form prescribed by the MCD and at a minimum will require the following:

(A) name and address of the applicant;

(B) name of contact person and telephone number;

(C) vehicle information;

(D) an indication as to whether the commodities to be transported will be agricultural or non-agricultural; and

(E) a list of counties in which the vehicle will operate.

(3) The application shall be accompanied by:

(A) a base fee of \$75 and an administration fee of \$5.00;

(B) an original bond or letter of credit as required in subsection (d) of this section, unless previously filed by the applicant; and

(C) an additional fee based on the following schedule:

Figure: 43 TAC §28.30(e)(3)(C)

Number of counties on permit application	Annual Fee
1-5	\$175
6-20	\$250
21-40	\$450
41-60	\$625
61-80	\$800
81-100	\$900
101-254	\$1,000

(4) Payment of fees. Fees for permits issued under this subchapter are payable as required by §28.11(f) of this chapter (relating to General Oversize/Overweight Permit Requirements and Procedures).

(f) Issuance of permit and windshield sticker.

(1) A permit and a windshield sticker will be issued on the approval of the application and each will be mailed to the applicant at the address contained in the application.

(2) The permit shall be carried in the vehicle for which the permit is issued at all times.

(3) The windshield sticker shall be affixed to the inside of the windshield of the vehicle within six inches above the vehicle's inspection sticker in a manner that will not obstruct the vision of the driver. Any attempt to remove the sticker from the windshield will render the sticker void, and will require a new permit and sticker. The windshield sticker must be removed from the vehicle upon expiration of the permit.

(4) A replacement sticker for a lost, stolen, or mutilated windshield sticker may be issued, provided that the permittee submits a request on a form approved by the department which shall include a statement, signed by the permittee, affirming that the sticker was lost, stolen, or mutilated. The replacement sticker shall only be valid for the permitted vehicle. The cost for a replacement sticker is \$3.00.

(5) Within 14 days of issuance of the permit, the department shall notify the county clerk of each county indicated on the application, and such notification shall contain or be accompanied by the following minimum information:

(A) the name and address of the person for whom a permit is issued; and

(B) the vehicle identification number, license plate number, and registration state of the vehicle, and the permit number.

(g) Issuance of a credit. Upon written application on a form prescribed by the MCD, a prorated credit for the remaining time on the permit may be issued for a vehicle that is destroyed or otherwise becomes permanently inoperable to an extent that it will no longer be utilized. The date for computing a credit will be based on the date of receipt of the credit request. The fee for a credit will be \$25, and will be issued on condition that the applicant provides to the department:

(1) the original permit; or

(2) if the original permit no longer exists, written evidence of the destruction or permanent incapacity from the insurance carrier of the vehicle.

(h) Use of credit. A credit issued under subsection (g) of this section may be used only towards the payment of permit fees under this section.

(i) Exceptions. A vehicle carrying timber, wood chips, wood pulp, cotton, or other agricultural products in their natural state, may be allowed to exceed the maximum allowable axle weight by 12% without a permit; however, if such vehicle exceeds the maximum allowable gross weight by an amount of up to 5.0%, a permit issued in accordance with this section will be required.

(j) Semi-trailer registration. Transportation Code, §502.167, provides that the owner of a semi-trailer registered with either a Texas token trailer license plate or a Texas apportioned trailer license plate operated in combination with a permitted vehicle, shall pay a \$15 fee to the county where the semi-trailer is registered.

(k) Lapse or termination of permit. A permit shall lapse or terminate and the windshield sticker must be removed from the vehicle:

(1) when the lease of the vehicle expires;

(2) on the sale of the vehicle for which the permit was issued;

(3) on the sale, takeover, or dissolution of the firm, partnership, or corporation to which a permit was issued; or

(4) if the applicant does not replenish the letter of credit or bond as required in subsection (d) of this section.

(l) Void permit. A permit will be voided when the department is informed by law enforcement that a citation has been issued for a violation of a permit's terms and conditions.

(m) Movement with void permit. A permittee may not operate a permitted vehicle with a void permit; a new permit must be obtained.

SUBCHAPTER D – PERMITS FOR OVERSIZE AND OVERWEIGHT OIL WELL RELATED VEHICLES

Rules

RULE §28.40 Purpose and Scope

In accordance with Transportation Code, Chapter 623, Subchapter G, the department may issue a permit for the operation of an oil well clean-out, drilling, servicing, or swabbing unit, which is a piece of fixed-load mobile machinery or equipment used for the purpose of cleaning out, drilling, servicing or swabbing oil wells, when the unit cannot comply with one or more of the restrictions set out in Transportation Code, §621.101. The sections in this subchapter set forth the requirements and procedures applicable to those permits.

RULE §28.41 General Requirements

(a) General information.

(1) Permits issued under this subchapter, with the exception of permits issued under §28.45 of this title (relating to Permits for Vehicles Transporting Liquid Products Related to Oil Well Production), are subject to the requirements of this section.

(2) Oil well related vehicles are eligible for:

- (A) single-trip mileage permits;
- (B) quarterly hubometer permits; and
- (C) annual permits.

(b) Prerequisites to obtaining an oversize/overweight permit. A unit permitted under this subchapter must be registered under Transportation Code, Chapter 502, for the maximum gross weight applicable to the vehicle under Transportation Code, §621.101, or have the distinguishing license plates as provided by Transportation Code, §504.504, if applicable to the vehicle.

(c) Payment of permit fees. Fees for permits issued under this subchapter are payable as described in §28.11(f) of this title (relating to General Oversize/Overweight Permit Requirements and Procedures).

(d) Restrictions.

(1) A vehicle permitted under this subchapter is subject to the restrictions specified in §28.11(l) of this title, and the permittee is responsible for obtaining information concerning current restrictions from the department.

(2) Vehicles permitted under this subchapter may not cross a load restricted bridge when exceeding the posted capacity of such. Vehicles permitted under this subchapter may travel on a load restricted road unless otherwise noted.

(3) A vehicle permitted under this subchapter may travel through highway construction or maintenance areas provided the dimensions do not exceed the construction restrictions as published by the department.

(4) A unit exceeding nine feet in width, 14 feet in height, or 65 feet in length is restricted to daylight movement only.

(e) Void permits. A permit will be voided when the department is informed by law enforcement that a citation has been issued for a violation of a permit's terms and conditions.

(f) Transferability. Unless otherwise noted, a permit issued under this subchapter may not be transferred between units or permittees.

(g) Records retention. A unit permitted under this section must keep the permit and any attachments to the permit in the unit until the day after the date the permit expires.

(h) Escort requirements. In addition to any other escort requirements specified in this subchapter, vehicles permitted under this subchapter are subject to the escort requirements specified in §28.11(k) of this title.

RULE §28.42 Single-Trip Mileage Permits

(a) General information.

(1) Permits issued under this section are subject to the requirements of §28.41 of this title (relating to General Requirements).

(2) A single-trip mileage permit:

(A) is limited to a maximum of seven consecutive days;

(B) routes the vehicle from the point of origin to the point of destination and has the route listed on the permit; and

(C) allows the unit to be returned to the point of origin on the same permit, provided the return trip is made within the time period stated in the permit.

(3) A unit exceeding 175,000 pounds gross weight must:

(A) have front and rear escort vehicles to prevent traffic from traveling beside the unit as it crosses a bridge;

(B) cross all multi-lane bridges by centering the unit on a lane line;

(C) cross all two-lane bridges in the center of the bridge; and

(D) cross each bridge at a speed not greater than 20 miles per hour.

(4) A unit exceeding 12 feet in width must be centered in the outside traffic lane of any highway that has paved shoulders.

(b) Maximum permit weight limits.

(1) The maximum permit weight for any single axle, not connected to another axle by a weight equalizing suspension system, must not exceed 30,000 pounds or 850 pounds per inch of tire width, whichever is less.

(2) The maximum permit weight for any group of axles on a unit will be determined by calculating the "W" weight for the group, using the formulas shown in Appendix B, titled "Maximum Permit Weight Formulas," and comparing the calculated "W" weight with the corresponding "W" weight that

is established in Appendix A, titled “Maximum Permit Weight Table,” both as shown in subsection (f) of this section.

(3) The maximum permit weight per inch of tire width for axles that are steerable must not exceed 950 pounds, and the maximum permit weight per inch of tire width for axles that are not steerable must not exceed 850 pounds.

(4) A unit that does not have any group of axles that exceeds the limits established in Appendix A, “Maximum Permit Weight Table,” and Appendix B, “Maximum Permit Weight Formulas,” as shown in subsection (f) of this section, will be permitted with a single-trip mileage or quarterly hubometer permit for travel on any route that does not include a load restricted bridge.

(5) A unit that has any group of axles that exceeds the limits established by Appendix A, “Maximum Permit Weight Table,” and Appendix B, “Maximum Permit Weight Formulas,” as shown in subsection (f) of this section, will be eligible, on an individual case-by-case basis, for a single-trip mileage permit only; permit approval or denial will be based on a detailed route study and an analysis of each bridge on the proposed travel route to determine if the route and bridges are capable of sustaining the movement.

(6) A bridge that has been analyzed and determined to be incapable of sustaining the unit will be excluded from the permit route.

(c) Permit application and issuance.

(1) Application for single-trip mileage permit.

(A) The applicant must submit the completed application to the MCD by telephone, facsimile, mail, or Internet. The application shall include, at a minimum, the following information:

- (i) name and address of applicant;
- (ii) origin and destination points of the unit;
- (iii) make and model of the unit;
- (iv) vehicle identification number of the unit;
- (v) license plate number of the unit;
- (vi) size and weight dimensions; and
- (vii) any other information required by law.

(B) Upon receipt of the application, the MCD will review and verify unit size and weight information, check route and mileage to be traveled, compute the permit fee, and advise the applicant of the permit fee.

(2) Issuance of single-trip mileage permit. Upon receipt of the permit fee, the MCD will advise the applicant of the permit number, and will provide a copy of the permit to the applicant if requested to do so.

(d) Permit fees and refunds.

(1) Minimum fee. The minimum fee for a single-trip mileage permit is either the calculated permit fee or \$31, whichever is the greater amount.

(2) Permit fee calculation. The fee for a single-trip mileage permit is calculated by the following formula.

Figure 1:43 TAC §28.42(d)(2)

Actual Mileage to be Traveled	X	Highway Use Factor	X	Total Rate Per Mile	X	Registration Reduction	+	Indirect Cost Share	=	Permit Fee
-------------------------------	---	--------------------	---	---------------------	---	------------------------	---	---------------------	---	------------

(A) Highway use factor. The highway use factor for a single trip mileage permit is 0.6.

(B) Total rate per mile. The total rate per mile is the combined mileage rates for width, height, and weight for the unit.

(i) The mileage rate for width is \$.06 per mile for each foot (or fraction thereof) above legal width.

(ii) The mileage rate for height is \$.04 per mile for each foot (or fraction thereof) above legal height.

(iii) The mileage rate for a single axle or any axle within a group that exceeds 20,000 pounds, but is less than or equal to 25,000 pounds, is calculated by multiplying \$.045 times the amount by which the axle or axle group weight exceeds the legal weight for the axle or axle group and dividing the resultant figure by 1,000 pounds.

(iv) The mileage rate for a single axle or any axle within a group that exceeds 25,000 pounds, but is less than or equal to 30,000 pounds, is calculated by multiplying \$.055 times the amount by which the axle or axle group weight exceeds the legal weight for the axle or axle group and dividing the resultant figure by 1,000 pounds.

(C) Registration reduction. A unit registered for maximum legal weight will receive a reduction of 25% in the computation of the permit fee.

(D) Indirect cost share. The indirect cost share is a prorated share of administering department activities, other than the direct cost of the activities, including the cost of providing statewide support services. The indirect cost share factor is based upon the previous year's expenditures.

(3) Permit fees for trailer mounted units.

(A) The permit fee for a trailer mounted unit is based on the overall width, overall height, and all axle weights, including the truck-tractor axles.

(B) A unit with two or more axle groups that do not have a spacing of at least 12 feet between the closest axles of the opposing groups must have the permit fee calculated by the following method.

(i) The axle group with the lowest weight will have the axle closest to the next axle group temporarily disregarded from its group in order to create a spacing of at least 12 feet between the two groups for fee calculation purposes.

(ii) An axle group will not have more than one axle disregarded.

(iii) The permit fee for the axle group with the temporarily disregarded axle must be based on the actual weight of the entire axle group minus the legal weight for the remaining axles of the group.

(4) Refunds. Fees for permits issued under this section are non-refundable.

(e) Amendments. A single-trip mileage permit may not be amended unless an exception is granted by the MCD.

(f) Appendices. The following table entitled “Maximum Permit Weight Table” is Appendix A, and the list of formulas entitled, “Maximum Permit Weight Formulas,” is Appendix B.

Figure 2:43 TAC §28.42(f)

Appendix A					
Maximum Permit Weight Table					
Length (L) Feet	Weight (W) (lb/ft)	Length (L) Feet	Weight (W) (lb/ft)	Length (L) Feet	Weight (W) (lb/ft)
4	7520	30	3676	55	3111
5	6345	31	3646	56	3094
6	5947	32	3616	57	3077
7	5698	33	3586	58	3061
Length (L) Feet	Weight (W) (lb/ft)	Length (L) Feet	Weight (W) (lb/ft)	Length (L) Feet	Weight (W) (lb/ft)
8	5500	34	3557	59	3045
9	5326	35	3529	60	3030
10	5169	36	3501	61	3015
11	5027	37	3474	62	3000
12	4898	38	3448	63	2985
13	4781	39	3423	64	2971
14	4675	40	3399	65	2957
15	4579	41	3376	66	2943
16	4492	42	3354	67	2929
17	4413	43	3333	68	2915
18	4340	44	3313	69	2901
19	4272	45	3293	70	2887
20	4208	46	3274	71	2874
21	4146	47	3255	72	2861
22	4087	48	3236	73	2848
23	4030	49	3218	74	2835
24	3974	50	3200	75	2822
25	3920	51	3182	76	2809
26	3867	52	3164	77	2796
27	3815	53	3146	78	2783
28	3764	54	3128	79	2771
29	3714	55	3111	80	2759

Appendix B

Maximum Permit Weight Formulas

$$W = T / (L + 4)$$

“W” - The value of the equivalent distributed load expressed in pounds per linear foot.

“T” - The sum of the axle loads or equivalent axle loads of any group of two or more axles expressed in pounds. Any combination of axle loads may be considered as a group, up to the total number of axles for the unit.

“L” - The length between axles, expressed in feet and measured to the nearest inch, from the center of the first axle to the center of last axle in the axle group, series of groups, or total axles for the unit.

A unit with axle groups composed of various numbers of tires per axle or with axle groups with a gauge distance greater than 6.0 feet on each axle may have additional reduction factors applied to each axle before summing “T.” The revised equivalent axle load is calculated by the following formula.

$$A = (RS)(\text{THE AXLE LOAD})$$

“A” - Equivalent axle load for axles with gauge greater than 6.0 feet and/or more than four tires. “R” - A reduction factor for a unit with a gauge distance greater than 6.0 feet, calculated by the following formula.

$$R = (6.0 + G) / (2 G)$$

“G” - The gauge distance, expressed in feet and measured to the nearest inch, from the center of the outside dual wheels on one side of the axle to the center of the outside dual wheels on the opposite side of the axle. The gauge distance of an axle equipped with two tires per axle must be measured to the nearest inch from center of tire to center of opposite tire.

“S” - A reduction factor based on the number of tires per axle. $S = 1.0$ for axles with four or fewer tires, and $S = 0.96$ for axles with eight tires.

RULE §28.43 Quarterly Hubometer Permits

(a) General information.

(1) Permits issued under this section are subject to the requirements of §28.41 of this title (relating to General Requirements).

(2) A quarterly hubometer permit:

(A) is effective for three consecutive months (for example, a permit issued with a beginning date of January 15 will terminate on April 14, or a permit issued with a beginning date of July 1 will terminate on September 30);

(B) allows the unit to travel on all state-maintained highways; and

(C) allows the unit to travel on a state-wide basis.

(3) A unit permitted under this subsection must not exceed any of the following dimensions:

(A) 12 feet in width;

(B) 14 feet, 6 inches in height; and

(C) 95 feet in length.

(4) With the exception of units that are overlength only, a unit operated with a permit issued under this section must be equipped with a hubometer. The permittee must maintain the hubometer in good working condition.

(5) A unit exceeding 175,000 pounds gross weight must:

(A) have front and rear escort vehicles to prevent traffic from traveling beside the unit as it crosses a bridge;

(B) cross all multi-lane bridges by centering the unit on a lane line;

(C) cross all two-lane bridges in the center of the bridge; and

(D) cross each bridge at a speed not greater than 20 miles per hour.

(b) Maximum permit weight limits.

(1) The maximum permit weight for any single axle, not connected to another axle by a weight equalizing suspension system, must not exceed 30,000 pounds or 850 pounds per inch of tire width, whichever is less.

(2) The maximum permit weight for any group of axles on a unit will be determined by calculating the “W” weight for the group, using the formulas in Appendix B, “Maximum Permit Weight Formulas”, and comparing the calculated “W” weight with the corresponding “W” weight that is established in Appendix A, “Maximum Permit Weight Table,” both as shown in §28.42(f) of this title (relating to Single Trip Mileage Permits).

(3) The maximum permit weight per inch of tire width for axles that are steerable must not exceed 950 pounds, and the maximum permit weight per inch of tire width for axles that are not steerable must not exceed 850 pounds.

(4) A unit that does not have any group of axles that exceeds the limits established in Appendix A, “Maximum Permit Weight Table,” and Appendix B, “Maximum Permit Weight Formulas,” as shown in §28.42(f) of this title, will be permitted with a single-trip mileage or quarterly hubometer permit for travel on any route that does not include a load restricted bridge.

(5) A unit that has any group of axles that exceeds the limits established by Appendix A, “Maximum Permit Weight Table,” and Appendix B, “Maximum

Permit Weight Formulas,” as shown in §28.42(f) of this title, will be eligible, on an individual case-by-case basis, for a single-trip mileage permit only; permit approval or denial will be based on a detailed route study and an analysis of each bridge on the proposed travel route to determine if the route and bridges are capable of sustaining the movement.

(6) A bridge that has been analyzed and determined to be incapable of sustaining the unit will be excluded from the permit route.

(c) Initial permit application and issuance.

(1) Initial permit application.

(A) The applicant for an initial quarterly hubometer permit must submit a completed application to the MCD by telephone, facsimile, mail, or Internet. The application shall include, at a minimum, the following information:

- (i) name and address of applicant;
- (ii) make and model of the unit;
- (iii) vehicle identification number of the unit;
- (iv) license plate number of the unit;
- (v) size and weight dimensions; and
- (vi) any other information required by law.

(B) Upon receipt of the initial quarterly hubometer permit application, the MCD will verify unit information, calculate the permit fee, and advise the applicant of the permit fee.

(2) Issuance of initial quarterly hubometer permit. Upon receipt of the permit fee, the MCD will provide the permit to the applicant if requested, and will also provide a renewal application form to the applicant.

(d) Permit renewals and closeouts.

(1) The applicant must complete and submit a renewal application form to the MCD for each permit that is to be renewed or closed out.

(2) Upon receipt of the renewal application, the MCD will verify unit information, check mileage traveled on the last permit, calculate the new permit fee, and advise the applicant of the permit fee.

(e) Permit fees and refunds.

(1) Minimum fee. The minimum fee for a quarterly hubometer permit is either the calculated permit fee or \$31, whichever is the greater amount.

(2) Fees for overlength units. A unit that is overlength only must obtain a quarterly hubometer permit with a fee of \$31, but is not required to have a hubometer.

(3) Quarterly hubometer permit fee calculation. The permit fee for a quarterly hubometer permit is calculated by the following formula.

Figure 1:43 TAC 28.43 (e) (3)

Hubometer Mileage	X	Highway Use Factor (3%)	X	Total Rate Per Mile	X	Registration Reduction	+	Indirect Cost Share	=	Permit Fee
----------------------	---	----------------------------------	---	------------------------------	---	---------------------------	---	---------------------------	---	---------------

(A) Hubometer mileage. Hubometer mileage for a quarterly hubometer permit is determined by an amount estimated by the applicant for the first quarterly hubometer permit, or from the unit's hubometer mileage reading from the previous quarterly hubometer permit.

(i) An applicant requesting a permit for a unit that has traveled in excess of the mileage stated in the previous quarterly hubometer permit must pay for the excess mileage traveled, in addition to the fee for the renewed quarterly hubometer permit.

(ii) An applicant requesting a permit for a unit that has traveled less than the mileage stated on the previous quarterly hubometer permit will receive a credit on the purchase price of the renewed quarterly hubometer permit for that unit or another unit.

(B) Highway use factor. The highway use factor for a quarterly hubometer permit is 0.3.

(C) Total rate per mile. The total rate per mile is the combined mileage rates for width, height, and weight for the unit.

(i) The mileage rate for width is \$.06 per mile for each foot (or fraction thereof) above legal width.

(ii) The mileage rate for height is \$.04 per mile for each foot (or fraction thereof) above legal height.

(iii) The mileage rate for a single axle or any axle within a group that exceeds 20,000 pounds, but is less than or equal to 25,000 pounds, is calculated by multiplying \$.045 times the amount by which the axle or axle group weight exceeds the legal weight for the axle or axle group and dividing the resultant figure by 1,000 pounds.

(iv) The mileage rate for a single axle or any axle within a group that exceeds 25,000 pounds, but is less than or equal to 30,000 pounds, is calculated by multiplying \$.055 times the amount by which the axle or axle group weight exceeds the legal weight for the axle or axle group and dividing the resultant figure by 1,000 pounds.

(D) Registration reduction. A unit registered for maximum legal weight will receive a reduction of 25% in the computation of the permit fee.

(E) Indirect cost share. The indirect cost share is a prorated share of administering department activities, other than the direct cost of the activities, including the cost of providing statewide support services. The indirect cost share factor is based upon the previous year's expenditures.

(4) Permit fees for trailer mounted units.

(A) The permit fee for a trailer mounted unit is based on the overall width, overall height, and all axle weights, including the truck-tractor axles.

(B) A unit with two or more axle groups that does not have a spacing of at least 12 feet between the closest axles of the opposing groups must have the permit fee calculated by the following method.

(i) The axle group with the lowest weight will have the axle closest to the next axle group temporarily disregarded from its group in order

to create a spacing of at least 12 feet between the two groups for fee calculation purposes.

(ii) An axle group will not have more than one axle disregarded.

(iii) The permit fee for the axle group with the temporarily disregarded axle must be based on the actual weight of the entire axle group minus the legal weight for the remaining axles of the group.

(5) Refunds. A refund is made to the applicant when the quarterly hubometer permit process is stopped for all units listed in the applicant's account, provided the amount of the refund exceeds \$25.

(f) Amendments. A quarterly hubometer permit may be amended only to indicate:

- (1) a new hubometer serial number; or
- (2) a new license plate number.

RULE §28.44 Annual Permits

(a) General information. Permits issued under this section are subject to the requirements of §28.41 of this title (relating to General Requirements).

(1) Annual self-propelled oil well servicing unit permits.

(A) A unit that does not exceed legal size and weight limits and is registered with a permit plate must purchase an annual permit issued under this section.

(B) The fee for an annual self-propelled oil well servicing unit permit is \$52 per axle. The indirect cost share is included in this fee.

(2) Annual oil field rig-up truck permits.

(A) An oil field rig-up truck permitted under this section must not exceed:

(i) legal height or length limits, as provided in Transportation Code, Chapter 623, Subchapter C;

(ii) 850 pounds per inch of tire width on the front axle;

(iii) 25,000 pounds on the front axle; or

(iv) legal weight on all other axles.

(B) An oil field rig-up truck, operating under an annual permit, must be registered in accordance with Transportation Code, Chapter 502.

(C) The annual permit fee for an oil field rig-up truck is \$52. The indirect cost share is included in this fee.

(D) An annual permit for an oil field rig-up truck allows the unit to travel at night, provided the unit does not exceed nine feet in width.

(3) A permit issued under this section may not be amended.

(4) A permit issued under this section allows travel on a statewide basis and on all state maintained highways.

(b) Permit application and issuance.

(1) Initial permit application. An applicant for an annual permit under this section must submit a completed application by telephone, facsimile,

mail, or Internet. The application shall include, at a minimum, the following information:

- (A) name and address of applicant;
- (B) make and model of the unit;
- (C) vehicle identification number of the unit;
- (D) license plate number of the unit;
- (E) size and weight dimensions; and
- (F) any other information required by law.

(2) Permit issuance. Upon receipt of the application and the appropriate fees, the MCD will provide the permit to the applicant if requested, and will also provide a renewal application form to the applicant.

RULE §28.45 Permits for Vehicles Transporting Liquid Products Related to Oil Well Production

(a) General provisions. This section applies to the following vehicles which may secure an annual permit issued under provisions of Transportation Code, Chapter 623, Subchapter G, to haul liquid loads over all state-maintained highways.

(1) A vehicle combination consisting of a truck-tractor and semi-trailer specifically designed with a tank and pump unit for transporting:

(A) liquid fracing products, liquid oil well waste products, or unrefined liquid petroleum products to an oil well; or

(B) unrefined liquid petroleum products or liquid oil well waste products from an oil well not connected to a pipeline.

(2) A permit issued under this section is effective for one year beginning on the “movement to begin” date.

(b) Application for permit.

(1) A request for an annual permit issued under Transportation Code, Chapter 623, Subchapter G, and this section, must be submitted to the MCD by telephone, facsimile, mail, or Internet.

(2) The permit request must be received by the MCD not more than 14 days prior to the date that the permit is to begin.

(c) Permit qualifications and requirements.

(1) The semi-trailer must be of legal size and weight.

(2) The semi-trailer must be registered for the maximum legal gross weight.

(3) Only one semi-trailer will be listed on a permit.

(4) The permit may be transferred from an existing trailer being removed from service and placed on a new trailer being added to the permittee’s fleet, if the permittee supplies the MCD with:

(A) the existing valid permit number;

(B) the make and model of the new trailer;

(C) the license number of the new trailer; and

(D) a transfer fee of \$31 per permit to cover administrative costs.

(d) Fees. All fees associated with permits issued under this section are payable as described in §28.11(f) of this title (relating to General Oversize/Overweight Permit Requirements and Procedures).

(1) The permit fee is based on the axles of the semi-trailer and the drive axles of the truck-tractor. The fee for the permit, which includes the indirect cost share, is determined as follows:

(A) \$52 per axle—to haul liquid oil well waste products or unrefined liquid petroleum products from oil wells not connected by a pipeline and return empty;

(B) \$52 per axle—to haul liquid products related to oil well production to an oil well and return empty; and

(C) \$104 per axle—to haul liquid products related to oil well production to an oil well and return with liquid oil well waste products or unrefined liquid petroleum products from an oil well not connected to a pipeline.

(2) Each permittee will be charged a \$20 issuance fee in addition to the permit fee.

(e) Permit movement conditions. The permit load must not cross any load-restricted bridge when exceeding the posted capacity of such.

SUBCHAPTER E – PERMITS FOR OVERSIZE AND OVERWEIGHT UNLADEN LIFT EQUIPMENT MOTOR VEHICLES

Rules

RULE §28.60 Purpose and Scope

In accordance with Transportation Code, Chapter 623, Subchapters I and J, the department may issue a permit for the operation of an oversize or overweight crane which is designed for use as lift equipment when the crane cannot comply with one or more of the restrictions set out in Transportation Code, Chapter 623, Subchapter C, and §621.101. The following sections in this subchapter set forth the requirements and procedures applicable to those permits.

RULE §28.61 General Requirements for Permits for Oversize and Overweight Unladen Lift Equipment Motor Vehicles

(a) General Information. Unless otherwise noted, permits issued under this subchapter are subject to the requirements of this section. Unladen lift equipment motor vehicles (cranes) permitted under this subchapter are eligible for:

(1) permit weight limits above those established by §28.11(d)(2) of this title (relating to General Oversize/Overweight Permit Requirements and Procedures);

(2) single-trip mileage permits;

(3) quarterly hubometer permits; and

(4) annual permits.

(b) Payment of permit fees. Fees for permits issued under this subchapter are payable as described in §28.11(f) of this title.

(c) Restrictions.

(1) A vehicle permitted under this subchapter is subject to the restrictions specified in §28.11(l) of this title, and the permittee is responsible for obtaining information concerning current restrictions from the department.

(2) A vehicle permitted under this subchapter may travel through highway construction or maintenance areas provided the dimensions do not exceed the construction restrictions as published by the department.

(d) Void permits. A permit will be voided when the department is informed by law enforcement that a citation has been issued for a violation of a permit's terms and conditions.

(e) Transferability. Unless otherwise noted, a permit issued under this subchapter may not be transferred between cranes or between permittees.

(f) Records retention. A crane permitted under this section must keep the permit and any attachments to the permit in the crane until the day after the date the permit expires.

(g) Escort requirements. In addition to any other escort requirements specified in this subchapter, cranes permitted under this subchapter are subject to the escort requirements specified in §28.11(k) of this title.

RULE §28.62 Single Trip Mileage Permits

(a) General information.

(1) Permits issued under this section are subject to the requirements of §28.61 of this title (relating to General Requirements for Permits for Oversize and Overweight Unladen Lift Equipment Motor Vehicles).

(2) A single trip mileage permit:

(A) is limited to a maximum of seven consecutive days;

(B) is routed from the point of origin to the point of destination and has the route listed on the permit; and

(C) allows the crane to be returned to the point of origin on the same permit, provided the return trip is made within the time period stated in the permit.

(3) A crane permitted under Transportation Code, Chapter 623, Subchapter J, must be registered under Transportation Code, Chapter 502, for the maximum gross weight applicable to the vehicle under Transportation Code, Section 621.101 or have the distinguishing license plates as provided by Transportation Code, §504.504 if applicable to the vehicle.

(4) A crane exceeding 175,000 pounds gross weight must:

(A) have front and rear escort vehicles to prevent traffic from traveling beside the crane as it crosses a bridge;

(B) cross all multi-lane bridges by centering the crane on a lane line;

(C) cross all two-lane bridges in the center of the bridge; and

(D) cross each bridge at a speed not greater than 20 miles per hour.

(5) A crane exceeding 12 feet in width must be centered in the outside traffic lane of any highway that has paved shoulders.

(6) The permitted vehicle must not cross a load restricted bridge when exceeding the posted capacity of such.

(b) Maximum permit weight limits.

(1) The maximum permit weight for any single axle, not connected to another axle by a weight equalizing suspension system, must not exceed 30,000 pounds or 850 pounds per inch of tire width, whichever is less.

(2) The maximum permit weight for any group of axles on a crane is determined by calculating the "W" weight for the group, using the formulas shown in Appendix B, "Maximum Permit Weight Formulas," and comparing the calculated "W" weight with the corresponding "W" weight that is established in Appendix A, "Maximum Permit Weight Table," both as shown in subsection (f) of this section.

(3) The maximum permit weight per inch of tire width for axles that are steerable must not exceed 950 pounds, and the maximum permit weight per inch of tire width for axles that are not steerable must not exceed 850 pounds.

(4) A crane that does not have any group of axles that exceeds the limits established in Appendix A, “Maximum Permit Weight Table,” and Appendix B, “Maximum Permit Weight Formulas,” both shown in subsection (f) of this section, will be permitted with a single-trip mileage permit or a quarterly hubometer permit for travel on any route that does not include a load restricted bridge.

(5) A crane that has any group of axles that exceeds the limits established by Appendix A, “Maximum Permit Weight Table,” and Appendix B, “Maximum Permit Weight Formulas,” shown in subsection (f) of this section, will be eligible, on an individual case-by-case basis, for a single-trip mileage permit only. Permit approval or denial will be based on a detailed route study and an analysis of each bridge on the proposed travel route to determine if the route and bridges are capable of sustaining the movement.

(6) A bridge that has been analyzed and determined to be incapable of sustaining the crane will be excluded from the permit route.

(c) Permit application and issuance.

(1) Application for single-trip mileage permit.

(A) The applicant must submit the completed application to the MCD by telephone, facsimile, mail, or Internet. The application shall include, at a minimum, the following information:

- (i) name and address of applicant;
- (ii) origin and destination points of the crane;
- (iii) make and model of the crane;
- (iv) vehicle identification number of the crane;
- (v) license plate number of the crane;
- (vi) size and weight dimensions; and
- (vii) any other information required by law.

(B) Upon receipt of the application, the MCD will review and verify size and weight information, check the route and mileage to be traveled, compute the permit fee, and advise the applicant of the permit fee.

(2) Issuance of single-trip mileage permit. Upon receipt of the permit fee, the MCD will advise the applicant of the permit number, and will provide a copy of the permit to the applicant if requested to do so.

(d) Permit fees and refunds.

(1) Minimum fee. The minimum fee for a single-trip permit is either the calculated permit fee or \$31, whichever is the greater amount.

(2) Permit fee calculation. The permit fee for a single-trip mileage permit is calculated by the following formula:

Figure 1: 43 TAC §28.62(d)(2)

Mileage to be Traveled	X	Highway Use Factor	X	Total Rate Per Mile	X	Registration Reduction	+	Indirect Cost Share	=	Permit Fee
------------------------	---	--------------------	---	---------------------	---	------------------------	---	---------------------	---	------------

(A) Highway use factor. The highway use factor for a single trip mileage permit is 0.6.

(B) Total rate per mile. The total rate per mile is the combined mileage rates for width, height, and weight for the unit.

(i) The mileage rate for width is \$.06 per mile for each foot (or fraction thereof) above legal width.

(ii) The mileage rate for height is \$.04 per mile for each foot (or fraction thereof) above legal height.

(iii) The mileage rate for a single axle or any axle within a group that exceeds 20,000 pounds, but is less than or equal to 25,000 pounds, is calculated by multiplying \$.045 times the amount by which the axle or axle group weight exceeds the legal weight for the axle or axle group and dividing the resultant figure by 1,000 pounds.

(iv) The mileage rate for a single axle or any axle within a group that exceeds 25,000 pounds, but is less than or equal to 30,000 pounds, is calculated by multiplying \$.055 times the amount by which the axle or axle group weight exceeds the legal weight for the axle or axle group and dividing the resultant figure by 1,000 pounds.

(C) Registration reduction. A crane registered for maximum legal weight will receive a reduction of 25% in the computation of the permit fee.

(D) Indirect cost share. The indirect cost share is a prorated share of administering department activities, other than the direct cost of the activities, including the cost of providing statewide support services. The indirect cost share factor is based upon the previous year's expenditures.

(3) Exceptions to fee computations. A crane with two or more axle groups that does not have a spacing of at least 12 feet between the closest axles of the opposing groups must have the permit fee calculated by the following method.

(A) The axle group with the lowest weight will have the axle closest to the next axle group temporarily disregarded from its group in order to create a spacing of at least 12 feet between the two groups for fee calculation purposes.

(B) An axle group will not have more than one axle disregarded.

(C) The permit fee for the axle group with the temporarily disregarded axle must be based on the actual weight of the entire axle group minus the legal weight for the remaining axles of the group.

(4) Refunds. Fees for permits issued under this section are non-refundable.

(e) Amendments. A single-trip mileage permit issued under this section may not be amended unless an exception is granted by the MCD.

(f) Appendices. The following table entitled "Maximum Permit Weight Table" is Appendix A, and the list of formulas entitled "Maximum Permit Weight Formulas," is Appendix B.

Figure 2:43 TAC §28.62(f)

Appendix A					
Maximum Permit Weight Table					
Length (L) Feet	Weight (W) (lb/ft)	Length (L) Feet	Weight (W) (lb/ft)	Length (L) Feet	Weight (W) (lb/ft)
4	7520	30	3676	55	3111
5	6345	31	3646	56	3094
6	5947	32	3616	57	3077
7	5698	33	3586	58	3061
8	5500	34	3557	59	3045
9	5326	35	3529	60	3030
10	5169	36	3501	61	3015
11	5027	37	3474	62	3000
12	4898	38	3448	63	2985
13	4781	39	3423	64	2971
14	4675	40	3399	65	2957
15	4579	41	3376	66	2943
16	4492	42	3354	67	2929
17	4413	43	3333	68	2915
18	4340	44	3313	69	2901
19	4272	45	3293	70	2887
20	4208	46	3274	71	2874
21	4146	47	3255	72	2861
22	4087	48	3236	73	2848
23	4030	49	3218	74	2835
24	3974	50	3200	75	2822
25	3920	51	3182	76	2809
26	3867	52	3164	77	2796
27	3815	53	3146	78	2783
28	3764	54	3128	79	2771
29	3714	55	3111	80	2759

Appendix B

Maximum Permit Weight Formulas

$$W = T / (L + 4)$$

“W” - The value of the equivalent distributed load expressed in pounds per linear foot.

“T” - The sum of the axle loads or equivalent axle loads of any group of two or more axles expressed in pounds. Any combination of axle loads may be considered as a group, up to the total number of axles for the unit.

“L” - The length between axles, expressed in feet and measured to the nearest inch, from the center of the first axle to the center of last axle in the axle group, series of groups, or total axles for the unit.

A unit with axle groups composed of various numbers of tires per axle or with axle groups with a gauge distance greater than 6.0 feet on each axle may have additional reduction factors applied to each axle before summing “T.” The revised equivalent axle load is calculated by the following formula.

$$A = (RS)(\text{THE AXLE LOAD})$$

“A” - Equivalent axle load for axles with gauge greater than 6.0 feet and/or more than four tires. “R” -A reduction factor for a unit with a gauge distance greater than 6.0 feet, calculated by the following formula.

$$R = (6.0 + G) / (2 G)$$

“G” - The gauge distance, expressed in feet and measured to the nearest inch, from the center of the outside dual wheels on one side of the axle to the center of the outside dual wheels on the opposite side of the axle. The gauge distance of an axle equipped with two tires per axle must be measured to the nearest inch from center of tire to center of opposite tire.

“S” - A reduction factor based on the number of tires per axle. $S = 1.0$ for axles with four or fewer tires, and $S = 0.96$ for axles with eight tires.

RULE §28.63 Quarterly Hubometer Permits

(a) General information.

(1) Permits issued under this section are subject to the requirements of §28.61 of this subchapter (relating to General Requirements for Permits for Oversize and Overweight Unladen Lift Equipment Motor Vehicles).

(2) A quarterly hubometer permit:

(A) is effective for three consecutive months (for example, a permit issued with a beginning date of January 15 will terminate on April 14, or a permit issued with a beginning date of July 1 will terminate on September 30);

(B) allows the vehicle to travel on all state-maintained highways; and

(C) allows the unit to travel on a state-wide basis.

(3) A crane permitted under this section must not exceed any of the following dimensions:

(A) 12 feet in width;

(B) 14 feet, 6 inches in height; or

(C) 95 feet in length.

(4) A crane permitted under this section must be registered under Transportation Code, Chapter 502, for the maximum gross weight applicable to the vehicle under Transportation Code, Section 621.101, or have the distinguishing license plates as provided by Transportation Code, §504.504, if applicable to the vehicle.

(5) With the exception of cranes that are overlength only, cranes operated with a quarterly hubometer permit must be equipped with a hubometer. The permittee must maintain the hubometer in good working condition.

(6) A crane exceeding 175,000 pounds gross weight must:

(A) have front and rear escort vehicles to prevent traffic from traveling beside the crane as it crosses a bridge;

(B) cross all multi-lane bridges by centering the crane on a lane line;

(C) cross all two-lane bridges in the center of the bridge; and

(D) cross each bridge at a speed not greater than 20 miles per hour.

(7) A crane exceeding 12 feet in width must be centered in the outside traffic lane of any highway that has paved shoulders.

(8) A crane will be permitted for night movement provided that it does not exceed 10 feet 6 inches in width, 14 feet in height, or 95 feet in length. A crane moving at night must be accompanied by a front and rear escort vehicle.

(9) The permitted vehicle must not cross a load restricted bridge when exceeding the posted capacity of such.

(10) The permit may be amended only to indicate:

(A) a new hubometer serial number; or

(B) a new license plate number.

(b) Maximum permit weight limits.

(1) The maximum permit weight for any single axle, not connected to another axle by a weight equalizing suspension system, must not exceed 30,000 pounds or 850 pounds per inch of tire width, whichever is less.

(2) The maximum permit weight for any group of axles on a crane will be determined by calculating the “W” weight for the group, using the formulas in Appendix B, “Maximum Permit Weight Formulas,” and comparing the calculated “W” weight with the corresponding “W” weight that is established in Appendix A, “Maximum Permit Weight Table,” as shown in §28.62(f) of this title (relating to Single Trip Mileage Permits).

(3) The maximum permit weight per inch of tire width for axles that are steerable must not exceed 950 pounds, and the maximum permit weight per inch of tire width for axles that are not steerable must not exceed 850 pounds.

(4) A crane that does not have any group of axles that exceeds the limits established in Appendix A, “Maximum Permit Weight Table,” and Appendix B, “Maximum Permit Weight Formulas,” as shown in §28.62(f) of this title, will be permitted with a single-trip mileage permit or a quarterly hubometer permit for travel on any route that does not include a load restricted bridge.

(5) A crane that has any group of axles that exceeds the limits established by Appendix A, “Maximum Permit Weight Table,” and Appendix B, “Maximum Permit Weight Formulas,” shown in §28.62(f) of this title, will be eligible, on an individual case-by-case basis, for a single-trip mileage permit only; permit approval or denial will be based on a detailed route study and an analysis of each bridge on the proposed travel route to determine if the route and bridges are capable of sustaining the movement.

(6) A bridge that has been analyzed and determined to be incapable of sustaining the crane will be excluded from the permit route.

(c) Initial permit application and issuance.

(1) Initial permit application.

(A) A completed application for an initial quarterly hubometer permit must be submitted to the MCD by telephone, facsimile, mail, or Internet. The application shall include, at a minimum, the following information:

- (i) name and address of applicant;
- (ii) make and model;
- (iii) the vehicle identification number;
- (iv) license plate number of the vehicle;
- (v) size and weight dimensions; and
- (vi) any other information required by law.

(B) Upon receipt of the initial quarterly hubometer permit application, the MCD will verify vehicle information, calculate the permit fee, and advise the applicant of the permit fee.

(2) Issuance of initial quarterly hubometer permit. Upon receipt of the permit fee, the MCD will provide the permit to the applicant upon request, and will also provide a renewal application form to the applicant.

(d) Permit renewals and closeouts.

(1) The applicant must complete and submit a renewal application form to the MCD for each permit that is to be renewed or closed out.

(2) Upon receipt of the renewal application, the MCD will verify crane information, check mileage traveled on the last permit, calculate the new permit

fee, and advise the applicant of the permit fee.

(e) Permit fees and refunds.

(1) Minimum fee. The minimum fee for a single-trip permit or time permit is either the calculated permit fee or \$31, whichever is the greater amount.

(2) Fees for overlength units. A crane that is overlength only must obtain a quarterly hubometer permit with a fee of \$31, and is not required to have a hubometer.

(3) Quarterly hubometer permit fee calculation. The permit fee for a quarterly hubometer permit is calculated by the following formula:

Figure 1: 43 TAC 28.63(e)(3)

Hubometer Mileage	X	Highway Use Factor (3%)	X	Total Rate Per Mile	X	Registration Reduction	+	Indirect Cost Share	=	Permit Fee
----------------------	---	----------------------------------	---	------------------------	---	---------------------------	---	---------------------------	---	---------------

(A) Hubometer mileage. Mileage for a quarterly hubometer permit is determined by an amount estimated by the applicant for the first quarterly hubometer permit, or from the crane’s hubometer mileage reading from the previous quarterly hubometer permit.

(i) An applicant requesting a permit for a crane that has traveled in excess of the mileage stated in the previous quarterly hubometer permit must pay for the excess mileage traveled, in addition to the fee for the renewed quarterly hubometer permit.

(ii) An applicant requesting a permit for a crane that has traveled less than the mileage stated on the previous quarterly hubometer permit will receive a credit on the purchase price of the renewed quarterly hubometer permit for that crane or another crane.

(B) Highway use factor. The highway use factor for a time permit is 0.3.

(C) Total rate per mile. The total rate per mile is the combined mileage rates for width, height, and weight for the crane.

(i) The mileage rate for width is \$.06 per mile for each foot (or fraction thereof) above legal width.

(ii) The mileage rate for height is \$.04 per mile for each foot (or fraction thereof) above legal height.

(iii) The mileage rate for a single axle or any axle within a group that exceeds 20,000 pounds, but is less than or equal to 25,000 pounds, is calculated by multiplying \$.045 times the amount by which the axle or axle group weight exceeds the legal weight for the axle or axle group and dividing the resultant figure by 1,000 pounds.

(iv) The mileage rate for a single axle or any axle within a group that exceeds 25,000 pounds, but is less than or equal to 30,000 pounds,

is calculated by multiplying \$.055 times the amount by which the axle or axle group weight exceeds the legal weight for the axle or axle group and dividing the resultant figure by 1,000 pounds.

(D) Registration reduction. A crane registered for maximum legal weight will receive a reduction of 25% in the computation of the permit fee.

(E) Indirect cost share. The indirect cost share is a prorated share of administering department activities, other than the direct cost of the activities, including the cost of providing statewide support services. The indirect cost share factor is based upon the previous year's expenditures.

(4) Special fee provisions. A crane with two or more axle groups that do not have a spacing of at least 12 feet between the closest axles of the opposing groups must have the permit fee calculated by the following method.

(A) The axle group with the lowest weight will have the axle closest to the next axle group temporarily disregarded from its group in order to create a spacing of at least 12 feet between the two groups for fee calculation purposes.

(B) An axle group will not have more than one axle disregarded.

(C) The permit fee for the axle group with the temporarily disregarded axle must be based on the actual weight of the entire axle group minus the legal weight for the remaining axles of the group.

(5) Refunds. The MCD will refund fees for permits issued under this section when the quarterly hubometer permit process is stopped for all cranes listed in the applicant's account, provided the amount of the refund exceeds \$25.

RULE §28.64 Annual Permits

(a) General information. Permits issued under this section are subject to the requirements of §28.61 of this title (relating to General Requirements for Permits for Oversize and Overweight Unladen Lift Equipment Motor Vehicles).

(1) A crane permitted under this section must not exceed:

(A) the weight limits established in §28.11(d)(1), (2) and (3) of this title (relating to General Oversize/Overweight Permit Requirements and Procedures);

(B) a gross weight of 120,000 pounds;

(C) legal length and height limits as specified in Transportation Code, §621.203 and §621.207; and

(D) 10 feet in width.

(2) A permit issued under this section may not be amended.

(3) A crane permitted under this section must not cross a load restricted bridge or a load restricted road when exceeding the posted capacity of such.

(4) A crane permitted under this section may travel at night with front and rear escort vehicles.

(5) The fee for an annual permit issued under this section is \$100.

(b) Permit application and issuance.

(1) Initial permit application. An applicant for an annual permit under this section must submit a completed application and the appropriate fees

by telephone, facsimile, mail, or Internet. The application shall include, at a minimum, the following information:

- (A) name and address of applicant;
- (B) make and model of the crane;
- (C) vehicle identification number;
- (D) license plate number;
- (E) size and weight dimensions; and
- (F) any other information required by law.

(2) Permit issuance. Upon receipt of the application and the appropriate permit fee, the MCD will verify the application information, provide the permit to the applicant if requested, and also provide a renewal application form to the applicant.

This page intentionally left blank.

SUBCHAPTER F – HIGHWAY CROSSINGS BY OVERSIZE AND OVERWEIGHT VEHICLES AND LOADS

Rules

RULE §28.80 Purpose

In accordance with Transportation Code, Chapter 623, Subchapter C, a person, firm, or corporation may request authorization to operate a vehicle that does not comply with one or more of the restrictions of Transportation Code, Chapter 621, across the width of any road in the state highway system, other than a controlled-access highway as defined in Transportation Code, §223.001, from private property to other private property provided that the commission has contracted with the requester to indemnify the department for the cost of repair and maintenance to the portion of such highway crossed by such vehicles.

RULE §28.81 Surety Bond

The requester shall, prior to exercising any rights thereunder, execute an adequate surety bond in such amount as may be determined by the commission to compensate for the cost of maintenance and repairs as provided herein, approved by the state treasurer and the attorney general, with a corporate surety authorized to do business in this state, conditioned on the requester fulfilling the obligations of the contract.

RULE §28.82 Preparation of Contract

(a) The department will contract with the requester to indemnify the state for the cost of maintenance or repair to that portion of the highway crossed by vehicles which cannot comply with one or more restrictions of Transportation Code, Chapter 621.

(b) The department will, at the expense of the requester, periodically maintain and repair the vehicle crossing in accordance with established departmental regulations, specifications, and engineering standards and practices.

(c) If the proposed vehicle crossing requires initial upgrading or reconstruction to safely and adequately accommodate the vehicles which will be using the highway crossing, the requester will bear the entire cost of such work. Construction plans, specifications, traffic control plans, and any other related work will be provided by the requester at no cost to the state. At the sole option of the department, it may elect to do this work or provide for this work by separate contract, with the requester bearing the entire cost.

(d) The requester will be responsible for furnishing, installing, maintaining, and removing when no longer required all traffic control devices which are

required at the crossing to insure the safety of the traveling public. At the sole option of the department, it may elect to do this work or provide for this work by separate contract, with the requester bearing the entire cost. All traffic-control devices and flaggers, if required, shall be in accordance with the Texas Manual on Uniform Traffic Control Devices.

(e) The requester shall indemnify the department for the cost of maintenance and repair to the vehicle crossing. The requester shall, at the entire expense of the requester, provide and keep in force a surety bond in an amount determined by the state to cover the cost of such maintenance and repair. The bond will require approval by the attorney general and comptroller of public accounts.

(f) The requester shall keep the roadway free of debris and objectionable dust, lights, or noise.

(g) The requester shall provide the department with the department's certificate of insurance covering the latest insurance requirements for contractors doing state highway construction work.

(h) The responsibilities of the requester as set forth in the contract shall not be transferred, assigned, or conveyed to a third party without approval of the department.

(i) If, in the sole judgment of the department, it is determined at a future date that traffic conditions have so changed that the existence or use of the vehicle crossing is impeding maintenance, damaging the highway facility, impairing safety, or that the vehicle crossing is not being properly operated, or that it constitutes a nuisance, or if for any other reason it is in the department's judgment that such a facility is not in the public interest, the vehicle crossing shall be modified if corrective measures acceptable to both the department and the requester can be applied to eliminate the objectionable features of the facility or terminated and the use of the area as a vehicle crossing discontinued.

(j) Upon termination of the contract the department shall make an inspection of the crossing site. If additional repairs, modifications, or rehabilitation is required to return the highway to its original condition, the requester shall bear the entire expense of such work.

SUBCHAPTER G – PORT OF BROWNSVILLE PORT AUTHORITY PERMITS

Rules

RULE §28.90 Purpose

In accordance with Transportation Code, Chapter 623, Subchapter K, the department may authorize the Brownsville Navigation District of Cameron County, Texas (Port of Brownsville) to issue permits for the movement of oversize or overweight vehicles carrying cargo on State Highway 48/State Highway 4 between the Gateway International Bridge and the entrance to the Port of Brownsville, or on U.S. Highway 77/U.S. Highway 83 and State Highway 48/State Highway 4 between the Veterans International Bridge at Los Tomates and the entrance to the Port of Brownsville. This subchapter sets forth the requirements and procedures applicable to the issuance of permits by the Port of Brownsville for the movement of oversize and overweight vehicles.

RULE §28.91 Responsibilities

(a) Surety bond. The department may require the Port of Brownsville to post a surety bond in the amount of \$500,000 for the purpose of reimbursing the department for actual maintenance costs of State Highway 48/State Highway 4 and U.S. Highway 77/U.S. Highway 83 in the event that sufficient revenue is not collected from permits issued under this subchapter.

(b) Verification of permits. All permits issued by the Port of Brownsville shall be carried in the permitted vehicle. The Port of Brownsville shall provide access for verification of permit authenticity by law enforcement and department personnel.

(c) Training. The Port of Brownsville shall secure any training necessary for personnel to issue permits under this subchapter. The department may provide assistance with training upon request by the Port of Brownsville.

(d) Accounting. The department shall develop accounting procedures related to permits issued under this subchapter which the Port of Brownsville must comply with for the purpose of revenue collections and any payment made to the department under subsection (h) of this section.

(e) Audits. The department may conduct audits annually or upon direction by the executive director of all Port of Brownsville permit issuance activities. In order to insure compliance, audits will at a minimum include a review of all permits issued, financial transaction records related to permit issuance, review of vehicle scale weight tickets and monitoring of personnel issuing permits under this subchapter.

(f) Revocation of authority to issue permits. If the department determines as a result of an audit that the Port of Brownsville is not complying with this

subchapter, the executive director will issue a notice to the Port of Brownsville allowing 30 days to correct any non-compliance issue. If after 30 days it is determined that the Port of Brownsville is not in compliance, then the executive director may revoke the Port of Brownsville's authority to issue permits.

(1) Upon notification that its authority to issue permits under this subchapter has been revoked, the Port of Brownsville may appeal the revocation to the commission in writing.

(2) In cases where a revocation is being appealed, the Port of Brownsville's authority to issue permits under this subchapter shall remain in effect until the commission makes a final decision regarding the appeal.

(3) Upon revocation of authority to issue permits, termination of the maintenance contract, or expiration of this subchapter, all permit fees collected by the port, less allowable administrative costs, shall be paid to the department.

(g) Fees. Fees collected under this subchapter shall be used solely to provide funds for the payments provided for under Transportation Code, §623.213, less administrative costs.

(1) The permit fee shall not exceed \$80 per trip. The Port of Brownsville may retain up to 15% of such permit fees for administrative costs, and the balance of the permit fees shall be deposited in the state highway fund to be used for maintenance of State Highway 48/State Highway 4 and U.S. Highway 77/U.S. Highway 83.

(2) The Port of Brownsville may issue a permit and collect a fee for a permit issued under this subchapter for any vehicle or vehicle combination exceeding vehicle size or weight as specified by Transportation Code, Chapter 621, Subchapters B and C, originating at:

(A) the Gateway International Bridge traveling only on State Highway 48/State Highway 4 to the Port of Brownsville;

(B) the Port of Brownsville traveling on State Highway 48/State Highway 4 to the Gateway International Bridge;

(C) the Veterans International Bridge at Los Tomates, traveling on U.S. Highway 77/U.S. Highway 83 and State Highway 48/State Highway 4 to the entrance to Port of Brownsville; or

(D) the Port of Brownsville, traveling on State Highway 48/State Highway 4 and U.S. Highway 77/U.S. Highway 83 to the Veterans International Bridge at Los Tomates.

(h) Maintenance Contract. The Port of Brownsville shall enter into a maintenance contract with the department for the maintenance of State Highway 48/State Highway 4 between the Gateway International Bridge and the Port of Brownsville and the maintenance of U.S. Highway 77/U.S. Highway 83 and State Highway 48/State Highway 4 between the Veterans International Bridge at Los Tomates and the Port of Brownsville.

(1) Maintenance shall include, but is not limited to, routine maintenance, preventive maintenance, and total reconstruction of the roadway and bridge structures as determined by the department to maintain the current level of service.

(2) The Port of Brownsville may make direct restitution to the department for actual maintenance costs in lieu of the department filing against the surety bond described in subsection (a) of this section, in the event that sufficient revenue is not collected.

(i) Reporting. Brownsville Port Authority shall provide monthly and annual reports to the department's Finance Division regarding all permits issued and all fees collected during the period covered by the report. The report must be in a format approved by the department.

RULE §28.92 Permit Issuance Requirements and Procedures

(a) Permit application. Application for a permit issued under this subchapter shall be in a form approved by the department, and shall at a minimum include:

(1) the name of the applicant;

(2) date of issuance;

(3) signature of the director of the Port of Brownsville;

(4) a statement of the kind of cargo being transported;

(5) the maximum weight and dimensions of the proposed vehicle combination, including number of tires on each axle, tire size for each axle, distance between each axle, measured from center of axle to center of axle, and the specific weight of each individual axle when loaded;

(6) the kind and weight of each commodity to be transported, not to exceed loaded dimensions of 12' wide, 15'6" high, 110' long or 125,000 pounds gross weight;

(7) a statement of any condition on which the permit is issued;

(8) a statement that the cargo shall be transported over the most direct route using State Highway 48/State Highway 4 between the Gateway International Bridge and the Port of Brownsville, or using U.S. Highway 77/U.S. Highway 83 and State Highway 48/State Highway 4 between the Veterans International Bridge at Los Tomates and the Port of Brownsville;

(9) the location where the cargo was loaded; and

(10) the date or dates on which movement authorized by the permit is allowed.

(b) Permit issuance.

(1) General.

(A) The original permit must be carried in the vehicle for which it is issued.

(B) A permit is void when an applicant:

(i) gives false or incorrect information;

(ii) does not comply with the restrictions or conditions stated in the permit; or

(iii) changes or alters the information on the permit.

(C) A permittee may not transport an overdimension or overweight load with a voided permit.

(2) Payment of permit fee. The Port of Brownsville may determine acceptable methods of payment. All fees transmitted to the department must be in U.S. currency.

(c) Maximum permit weight limits.

(1) An axle group must have a minimum spacing of four feet, measured from center of axle to center of axle, between each axle in the group to achieve the maximum permit weight for the group.

(2) Two or more consecutive axle groups must have an axle spacing of 12 feet or greater, measured from the center of the last axle of the preceding group to the center of the first axle of the following group, in order for each group to be permitted for maximum permit weight.

(3) Maximum permit weight for an axle or axle group is based on 650 pounds per inch of tire width or the following axle or axle group weights, whichever is the lesser amount:

- (A) single axle—25,000 pounds;
- (B) two axle group—46,000 pounds;
- (C) three axle group—60,000 pounds;
- (D) four axle group—70,000 pounds;
- (E) five axle group—81,400 pounds; or
- (F) trunnion axles—60,000 pounds if;
 - (i) the trunnion configuration has two axles;
 - (ii) there are a total of 16 tires for a trunnion configuration; and
 - (iii) the trunnion axle as shown in the following diagram is 10 feet in width.

feet in width.

Figure: 43 TAC §28.92(c)(3)(F)(iii)

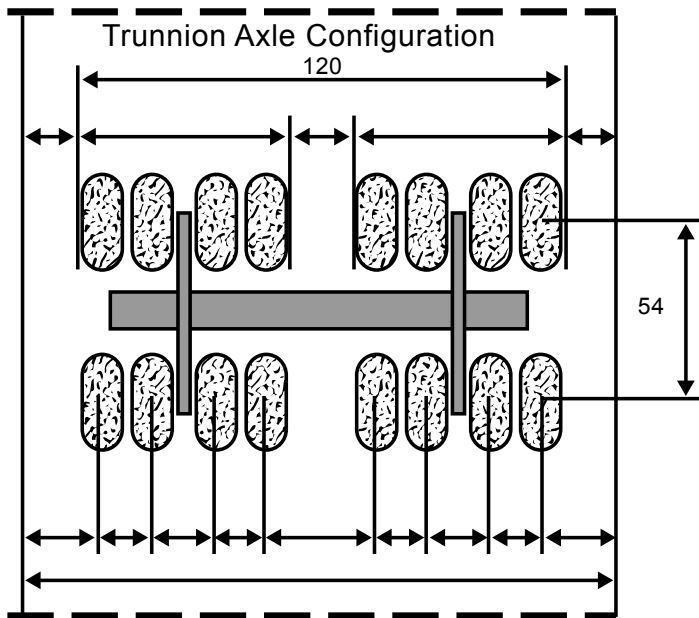

(4) A permit issued under this subchapter does not authorize the vehicle to exceed manufacturer's tire load rating.

(d) Vehicles exceeding weight limits. Any vehicle exceeding weight limits outlined in subsection (c) of this section, shall apply directly to the department for an oversize or overweight permit in accordance with §28.11 of this chapter (relating to General Oversize/Overweight Permit Requirements and Procedures).

(e) Registration. Any vehicle or combination of vehicles permitted under this subchapter shall be registered in accordance with Transportation Code, Chapter 502.

(f) Travel conditions. Movement of a permitted vehicle is prohibited when visibility is reduced to less than 2/10 of one mile or the road surface is hazardous due to weather conditions such as rain, ice, sleet, or snow, or highway maintenance or construction work.

(g) Daylight and night movement restrictions. An oversize permitted vehicle may be moved only during daylight hours; however, an overweight only permitted vehicle may be moved at any time.

(h) Restrictions.

(1) Any vehicle issued a permit by the Port of Brownsville must be weighed on scales capable of determining gross vehicle weights and individual axle loads. For the purpose of ensuring the accuracy of the permit, the scales must be certified by the Texas Department of Agriculture or accepted by the United Mexican States.

(2) A valid permit and certified weight ticket must be presented to the gate authorities before the permitted vehicle shall be allowed to exit or enter the port.

(3) The owner of a vehicle permitted under this subchapter must be registered as a motor carrier in accordance with Transportation Code, Chapters 643 or 645, prior to the oversize or overweight permit being issued. The Port of Brownsville shall maintain records relative to this subchapter, which are subject to audit by department personnel.

(4) Permits issued by the Port of Brownsville shall be in a form prescribed by the department.

(5) The maximum speed for a permitted vehicle shall be 55 miles per hour or the posted maximum, whichever is less.

This page intentionally left blank.

SUBCHAPTER H – CHAMBERS COUNTY PERMITS

Rules

RULE §28.100 Purpose

In accordance with Transportation Code, Chapter 623, Subchapter M, the commission may authorize Chambers County, Texas to issue permits for the movement of oversize and overweight vehicles and loads on the roads designated by Transportation Code, §623.252(b)(1). This subchapter sets forth the requirements and applicable procedures for the issuance of permits by Chambers County for the movement of oversize and overweight vehicles.

RULE §28.101 Responsibilities

(a) Authority to issue permits. Chambers County may issue a permit for a vehicle or vehicle combination that exceeds the vehicle size or weight limits specified by Transportation Code, Chapter 621, Subchapters B and C but does not exceed loaded dimensions of 12' wide, 16' high, or 110' long, or 100,000 pounds gross weight for travel on the roads designated by Transportation Code, §623.252(b)(1).

(b) Permit fees and administrative costs. Chambers County shall collect a fee for each permit issued under this subchapter. The permit fee may not exceed \$80 per trip. Chambers County may retain an amount up to 15 percent of each permit fee to cover costs of administering the program. The permit fee and administration costs shall be established by the agreement between the department and Chambers County. Chambers County shall deposit the permit fees collected, less administrative cost amounts authorized, in the State Highway Fund. The department will use those amounts for the maintenance and improvement of the roads designated by Transportation Code, §623.252(b)(1).

(c) Surety bond. The department may require Chambers County to post a surety bond in the amount of \$500,000 for the purpose of reimbursing the department the amount equal to the actual maintenance costs of roads designated by Transportation Code, §623.252(b)(1) less the amount that Chambers County deposits in the State Highway Fund under subsection (b) of this section.

(d) Verification of permits. All permits issued by Chambers County shall be carried in the permitted vehicle. Chambers County shall provide access for verification of permit authenticity by law enforcement and department personnel.

(e) Training. Chambers County shall secure any training necessary for personnel to issue permits under this subchapter. The department may provide assistance with training upon request by Chambers County.

(f) Accounting. The department shall develop accounting procedures related to permits issued under this subchapter. Chambers County shall comply with those accounting procedures for the purpose of revenue collections and any payment made to the department under subsection (i) of this section.

(g) Audits. The department may conduct annual audits of all Chambers County permit activities or upon direction by the executive director. In order to insure compliance, audits will at a minimum include a review of all permits issued, financial transaction records related to permit issuance, review of vehicle scale weight tickets, and monitoring of personnel issuing permits under this subchapter.

(h) Revocation of authority to issue permits. If the department determines as a result of an audit that Chambers County is not complying with this subchapter, the executive director will issue a notice to Chambers County allowing 30 days to correct any non-compliance issue. If after 30 days it is determined that Chambers County is not in compliance, then the executive director may revoke Chambers County's authority to issue permits.

(1) Upon notification that its authority to issue permits under this subchapter has been revoked, Chambers County may appeal the revocation to the commission in writing.

(2) In cases where a revocation is being appealed, Chambers County's authority to issue permits under this subchapter shall remain in effect until the commission makes a final decision regarding the appeal.

(3) Upon revocation of authority to issue permits, termination of the maintenance contract, or expiration of this subchapter, all permit fees collected by Chambers County, less allowable administrative costs, shall be paid to the department.

(i) Maintenance payments. If Chambers County does not deposit in the State Highway Fund under subsection (b) of this section sufficient amounts to reimburse the department for the payment of the costs of maintenance of the highways that are designated by Transportation Code, §623.252(b)(1), Chambers County may pay the deficiency in lieu of the department's filing against the surety bond provided under subsection (c) of this section for that amount. Maintenance includes routine maintenance, preventive maintenance, and total reconstruction of the roadway and bridge structures as determined by the department to maintain the current level of service.

(j) Reporting. Chambers County shall provide monthly and annual reports to the department's Finance Division regarding all permits issued and fees collected. The report must be in a format approved by the department.

RULE §28.102 Permit Issuance Requirements and Procedures

(a) Permit contents. A permit issued under this subchapter shall be in a form approved by the department, and shall at a minimum include:

- (1) the name of the applicant;
- (2) date of issuance;

- (3) signature of the designated agent of Chambers County;
- (4) the maximum weight and dimensions of the proposed vehicle combination including the number of tires on each axle, tire size for each axle, distance between each axle, measured from center of axle to center of axle, and the specific weight of each individual axle when loaded;
- (5) a statement of the kind and weight of each commodity to be transported, not to exceed loaded dimensions of 12' wide, 16' high, or 110' long, or 100,000 pounds gross weight;
- (6) a statement of any condition on which the permit is issued;
- (7) a statement that the cargo may be transported in Chambers County only over the roads that are described by Transportation Code, §623.652(b)(1);
- (8) the location where the cargo was loaded; and
- (9) the date or dates on which movement authorized by the permit is allowed.

(b) Permit use and validity.

(1) General.

(A) The original permit must be carried in the vehicle for which it is issued.

(B) A permit is void when an applicant:

(i) gives false or incorrect information;

(ii) does not comply with the restrictions or conditions stated in the permit; or

(iii) changes or alters the information on the permit.

(C) A permittee may not transport an overdimension or overweight load with a voided permit.

(2) Payment of permit fee. Chambers County may determine acceptable methods of payment. All fees transmitted to the department must be in U.S. currency.

(c) Maximum permit weight limits.

(1) An axle group must have a minimum spacing of four feet, measured from center of axle to center of axle, between each axle in the group, to achieve the maximum permit weight for the group.

(2) Two or more consecutive axle groups must have an axle spacing of 12 feet or greater, measured from the center of the last axle of the preceding group to the center of the first axle of the following group, in order for each group to be permitted for maximum permit weight.

(3) Maximum permit weight for an axle or axle group is based on 650 pounds per inch of tire width or the following axle or axle group weights, whichever is the lesser amount;

(A) single axle—25,000 pounds;

(B) two axle group—46,000 pounds;

(C) three axle group—60,000 pounds;

(D) four axle group—70,000 pounds;

(E) five axle group—81,400 pounds;

- (F) trunnion axles—60,000 pounds if:
- (i) the trunnion configuration has two axles;
 - (ii) there are a total of 16 tires for a trunnion configuration; and
 - (iii) the trunnion axle as shown in the following diagram is 10 feet in width.

Figure: 43 TAC §28.102(c)(3)(F)(iii)

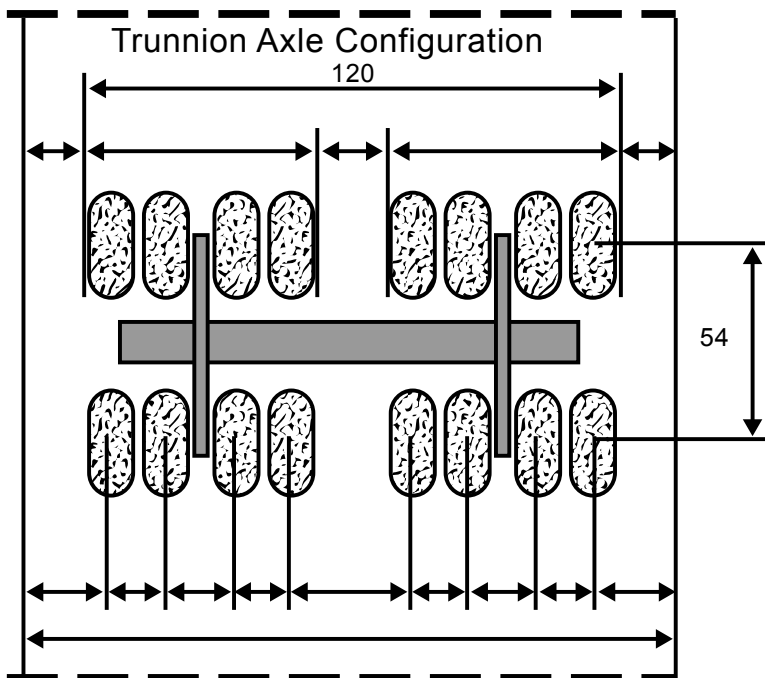

(4) A permit issued under this subchapter does not authorize the vehicle to exceed manufacturer's tire load rating.

(d) Vehicles exceeding weight limits. Any vehicle exceeding weight limits outlined in subsection (c) of this section, shall apply directly to the department for an oversize or overweight permit in accordance with §28.11 of this chapter (relating to General Oversize/Overweight Permit Requirements and Procedures).

(e) Registration. Any vehicle or combination of vehicles permitted under this subchapter shall be registered in accordance with Transportation Code, Chapter 502.

(f) Travel conditions. Movement of a permitted vehicle is prohibited when visibility is reduced to less than 2/10 of one mile or the road surface is hazardous due to weather conditions such as rain, ice, sleet, or snow, or highway maintenance or construction work.

(g) Daylight and night movement restrictions. An oversize permitted vehicle may be moved only during daylight hours; however, an overweight only

permitted vehicle may be moved at any time.

(h) Restrictions.

(1) Any vehicle issued a permit by Chambers County must be weighed on scales capable of determining permitted loaded gross vehicle weights and individual axle loads. For the purpose of ensuring the accuracy of the permit, the scales must be certified by the Texas Department of Agriculture.

(2) A copy of the certified weight ticket shall be retained by Chambers County and become a part of the official permit record subject to inspection by department personnel or Texas Department of Public Safety personnel.

(3) The owner of a vehicle permitted under this subchapter must be registered as a motor carrier in accordance with Transportation Code, Chapters 643 or 645, prior to the oversize or overweight permit being issued.

(4) Permits issued by Chambers County shall be in a form prescribed by the department.

(5) The maximum speed for a permitted vehicle shall be 55 miles per hour or the posted maximum, whichever is less.

(i) Records. Chambers County shall maintain records relative to this subchapter, which are subject to audit by department personnel.

(j) Issuing entity. A motor carrier transporting loads that fall within the size and weight limits of §28.101 of this subchapter (relating to Responsibilities) on trips originating and terminating within the Cedar Crossing Business Park using a road designated by Transportation Code, §623.252(b)(1) must obtain a permit from Chambers County.

This page intentionally left blank.

SUBCHAPTER I – COMPLIANCE

Rules

RULE §28.110 Purpose

The purpose of this subchapter is to provide for an efficient and effective system of enforcement of Transportation Code, Chapters 621, 622, and 623 by setting out procedures for citing violations related to the operation, with or without oversize or overweight permits, of vehicles or combination of vehicles on a public road or highway in the state in excess of the applicable maximum weight, height, length, or width.

RULE §28.111 Applicability

(a) A person operating or loading a vehicle for which a permit under this chapter is required shall comply with all applicable terms, conditions, and requirements of the permit, and with this chapter and Transportation Code, Chapters 621, 622, or 623 as applicable.

(b) A person loading a vehicle or operating on a public road or highway a vehicle for which a permit under this chapter is not required shall comply with the weight and size provisions of Transportation Code, Chapters 621, 622, or 623.

(c) Gross weight registration. A person may not operate on a highway or public road a vehicle that exceeds its gross weight registration.

RULE §28.112 Falsification of Information on Application and Permit

(a) A person who provides false information on the permit application or another form required by the department for the issuance of an oversize or overweight permit commits a violation of this chapter and is subject to revocation of an oversize or overweight permit and the enforcement provisions of Subchapter K of this chapter.

(b) A person violates this chapter if the person produces a counterfeit permit or alters a permit issued by the department.

RULE §28.113 Shipper Certificate of Weight

(a) For a shipper's certificate of weight to be valid, the shipper must:

(1) certify that the information contained on the form used for the shipper's certificate of weight is accurate; and

(2) deliver the certificate to the motor carrier or other person transporting the shipment before:

(A) the motor carrier or person applies for an overweight permit under this chapter; or

(B) the motor carrier or person begins to transport the shipment if the motor carrier or person does not apply for an overweight permit because of the information in the certificate.

(b) A motor carrier who holds an annual envelope permit issued under this chapter may rely on the shipper's certificate of weight to determine whether the shipment requires an additional overweight permit.

(c) It is an affirmative defense to an administrative enforcement action under this chapter for the failure of a person or the holder of a permit to obtain the required overweight permit that the person relied on a valid shipper's certificate of weight.

RULE §28.114 Compliance with Remote Permit System

A person who by contract is authorized by the department to access the electronic filing applications system shall comply with all of the requirements of the contract and any conditions placed on the permits.

RULE §28.115 Permits Issued by Another State

A permit issued by another state under an authorized reciprocal agreement is subject to this chapter and Transportation Code, Chapters 621, 622, or 623 as applicable, as if the permit were issued by the department.

RULE §28.116 Permit Compliance

A permit issued under this chapter becomes invalid immediately on the violation of a rule or a condition or requirement placed on the permit. Movement over a highway or public road of the vehicle for which the permit was issued after the permit becomes invalid under this section is a violation of this chapter and subject to enforcement action under this chapter and Transportation Code, Chapter 621, 622, or 623.

SUBCHAPTER J – RECORDS AND INSPECTIONS

Rules

RULE §28.200 Purpose

The purpose of this subchapter is to advise persons who are subject to Transportation Code, Chapters 621, 622, or 623 of the information and records that they are required to maintain, where and how long the records must be maintained, and department procedures for examining and inspecting these records.

RULE §28.201 Investigations and Inspections of Records

(a) Inspections.

(1) A person shall give an inspector access to the person's premises to conduct inspections or investigations of an alleged violation of this chapter or Transportation Code, Chapters 621, 622, or 623. The person shall provide adequate workspace with reasonable working conditions and shall allow the inspector to copy and verify records.

(2) The inspector will conduct inspections and investigations during normal business hours unless mutual arrangements have been made otherwise.

(3) The inspector will present to the person the inspector's credentials and a written statement from the department indicating the inspector's authority to conduct the investigation.

(b) Access.

(1) Except as provided by paragraph (2) of this subsection, a person shall provide access to requested records at:

(A) the person's principal place of business; or

(B) a location in this state agreed to by the department and the person.

(2) If the person's principal place of business is located outside of this state, the person may choose to make the records available at an out-of-state location agreed to by the department and the person but only if the person agrees to reimburse the department for necessary travel expenses and for a per diem as set by legislative appropriation for each day that an inspection or investigation related to the records or information is conducted.

(3) If the requested records are maintained at the person's principal place of business in this state, the person shall make those records available to the inspector immediately after the department requests the records. If the records are maintained at a regional office or driver work-reporting location or if the person's principal place of business is located outside of this state, the person shall make the records available at the person's principal place of business or the

agreed location at a time agreed to by the department and the person within 48 hours after the time that the department makes the request. Saturdays, Sundays, and federal and state holidays are excluded from the computation of the 48-hour period.

(c) If a time or location cannot be agreed upon under subsection (b) of this section, the department shall designate the time or location by certified mail or facsimile.

RULE §28.202 Records

(a) General records to be maintained. Each person who is subject to this chapter shall maintain the following records if information in such a record is necessary to verify the person's operation:

(1) operational logs, insurance certificates, and documents to verify the person's operations;

(2) complete and accurate records of services performed; and

(3) all certificate of title documents, shipper's certificate of weight, including information used to support the shipper's certificate of weight, weight tickets, permits for oversize or overweight vehicles and loads, dispatch records, load tickets, waybill or any other document that verify the operations of the vehicle to determine the actual weight, insurance coverage, size or capacity of the vehicle, and the size or weight of the commodity being transported.

(b) Copies of permits. A copy of the oversize or overweight permit shall be maintained in the vehicle for which the permit was issued during the period that the permit is required. On demand by a department inspector or any other authorized government personnel, the driver of the vehicle shall present the permit to that person.

(c) Preservation and destruction of records. Records required under this section shall be maintained for not less than two years, except that drivers' time cards and logs shall be maintained for not less than six months.

SUBCHAPTER K – ENFORCEMENT

Rules

RULE §28.300 Purpose

The purpose of this subchapter is to provide for an efficient and effective system of enforcement of Transportation Code, Chapters 621, 622, and 623 and the rules adopted under those chapters by setting out procedures for administrative penalties, revocation, and denial of oversize or overweight permits.

RULE §28.301 Administrative Penalties

(a) Authority. The department may impose an administrative penalty against a person who:

(1) provides false information on a permit application or another form provided to the department concerning the issuance of an oversize or overweight permit;

(2) violates this chapter or Transportation Code, Chapters 621, 622, or 623;

(3) violates an order adopted under this chapter or Transportation Code, Chapters 621, 622, or 623; or

(4) fails to obtain an oversize or overweight permit that is required under this chapter or Transportation Code, Chapters 621, 622, or 623.

(b) Amount of penalty.

(1) Except as provided by this section, the amount of the penalty may not exceed \$5,000 for each violation.

(2) If it is found that the person knowingly committed a violation, the penalty for that violation may be in an amount not to exceed \$15,000. A person acts knowingly if the person acts with knowledge that the act constitutes or violates Transportation Code, Chapters 621, 622, or 623, this chapter, or an order adopted under this chapter.

(3) If it is found that the person knowingly committed multiple violations, the aggregate penalty for the multiple violations may be in an amount not to exceed \$30,000. Multiple violations are all violations arising during a single episode under one scheme or course of conduct.

(4) Each day a violation continues or occurs is a separate violation for purposes of imposing a penalty under this section.

(5) Amount of penalty. Any recommendation that a penalty should be imposed must be based on the following factors:

(A) the seriousness of the violation, including the nature, circumstances, extent, and gravity of any prohibited acts, and the hazard or potential hazard created to the health, safety, or economic welfare of the public;

(B) the economic harm to property or the environment caused by the violation;

- (C) the history of previous violations;
- (D) the amount necessary to deter future violations;
- (E) efforts made to correct the violation; and
- (F) any other matters that justice may require.

RULE §28.302 Administrative Sanctions

(a) The department may revoke, suspend, or deny an oversize or overweight permit if the person or permit holder:

(1) provides false information on the permit application or another form provided to the department concerning the issuance of an oversize or overweight permit;

(2) violates this chapter or Transportation Code, Chapters 621, 622, or 623;

(3) violates an order adopted under this chapter or Transportation Code, Chapters 621, 622, or 623; or

(4) fails to obtain an oversize or overweight permit that is required under this chapter or Transportation Code, Chapters 621, 622, or 623.

(b) The department may probate a suspension ordered under this section.

(1) In determining whether to probate a suspension, the department will review:

(A) the seriousness of the violation;

(B) prior violations by the person;

(C) whether the department has previously probated a suspension for the person;

(D) cooperation by the person in the investigation and enforcement proceeding; and

(E) the ability of the person to correct the violations.

(2) The department shall set the length of the probation based on the seriousness of the violation and previous violations by the person.

(3) The department will require that the person whose suspension is probated report monthly to the department any information necessary to determine compliance with the terms of the probation.

(4) The department may revoke the probation and impose a deferred administrative penalty if the person fails to abide by any terms of the probation.

RULE §28.303 Implications for Nonpayment of Penalties; Grounds for Action

The department may not issue an oversize or overweight permit to the person who has not paid an administrative penalty that is due or for the vehicle that is the subject of the enforcement order until the amount of the delinquent administrative penalty has been paid to the department.

RULE §28.304 Administrative Proceedings

(a) If the department decides to take an enforcement action under §28.301 or §28.302 of this subchapter, the department shall give written notice to the person against whom the action is being taken by first class mail to the person's address as shown in the records of the department.

(b) The notice required by subsection (a) of this section must include:

- (1) a brief summary of the alleged violation;
- (2) a statement of each enforcement action being taken;
- (3) the effective date of each enforcement action;
- (4) a statement informing the person of the person's right to request a hearing;

(5) a statement describing the procedure for requesting a hearing, including the period during which a hearing request must be made; and

(6) a statement that the proposed penalties and sanctions will take effect on the date specified in the letter if the person fails to request a hearing.

(c) The person must submit a written request for a hearing to the address provided in the notice not later than the 26th day after the date the notice required by subsection (a) of this section is mailed.

(d) On receipt of the written request for a hearing, the department will refer the matter to the State Office of Administrative Hearings. When the hearing is set, the department will give notice of the time and place of the hearing to the person.

(e) If the person does not make a written request for a hearing or enter into a settlement agreement under §28.305 of this subchapter before the 27th day after the date that the notice is mailed, the department's decision becomes final and unappealable on that date.

RULE §28.305 Settlement Agreements

(a) The department and the alleged violator may enter into a compromise settlement agreement at any time before the issuance of a final decision. The compromise settlement agreement must provide that the alleged violator consents to the assessment of a specified administrative penalty or to the imposition of the specified administrative sanction by the department against the alleged violator and must be signed by the alleged violator and the director. A compromise agreement is not an admission of the alleged violation.

(b) If the settlement agreement requires the payment of a penalty to the department, the alleged violator must submit a cashier's check or money order to the department in the agreed amount before the agreement may be executed.

(c) The settlement agreement must include a clause that authorizes the department to revoke the settlement agreement and initiate a hearing on the alleged violations if the alleged violator fails to abide by the terms of the settlement agreement.

(d) Upon the execution by the director of a settlement agreement, the administrative proceeding ends. The settlement agreement is a department order that is final and unappealable.

RULE §28.306 Administrative Penalty for False Information on Certificate by a Shipper

(a) The department may investigate and impose an administrative penalty on a shipper who provides false information on a shipper's certificate of weight that the shipper delivers to a person transporting a shipment.

(b) The notice and hearing requirements of §28.304 of this subchapter apply to the imposition of an administrative penalty under this section.

(c) The amount of an administrative penalty imposed under this section is calculated in the same manner as the amount of an administrative penalty imposed under §28.301 of this subchapter.